

* FINISHES AVAILABLE :
 # 8 POLISHED & # 4 SATIN
 STAINLESS
 US3 POLISHED & US4 SATIN
 BRASS (NON LACQUER COATED)
 US10B
 ANODIZED PAINTED

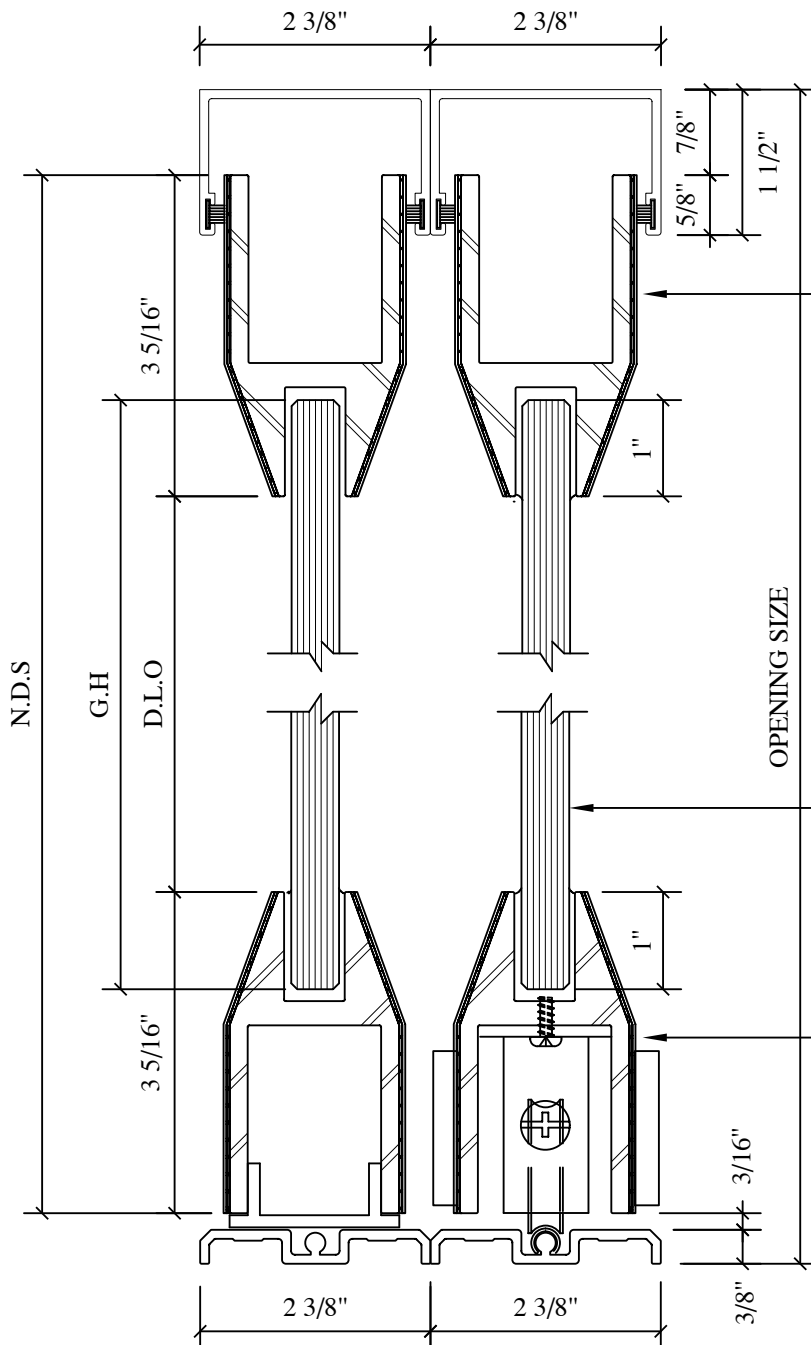
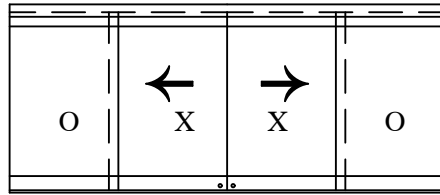

PL150 CLAD
 BY P.R.L GLASS

GLASS HEIGHT = D.L.O + 2"

1/2" CLEAR TEMPERED
 GLASS
 BY P.R.L GLASS

PL 150 CLAD
 BY P.R.L GLASS

* FINISHES AVAILABLE :
8 POLISHED & # 4 SATIN
STAINLESS
US3 POLISHED & US4 SATIN
BRASS (NON LACQUER COATED)
US10B
ANODIZED PAINTED

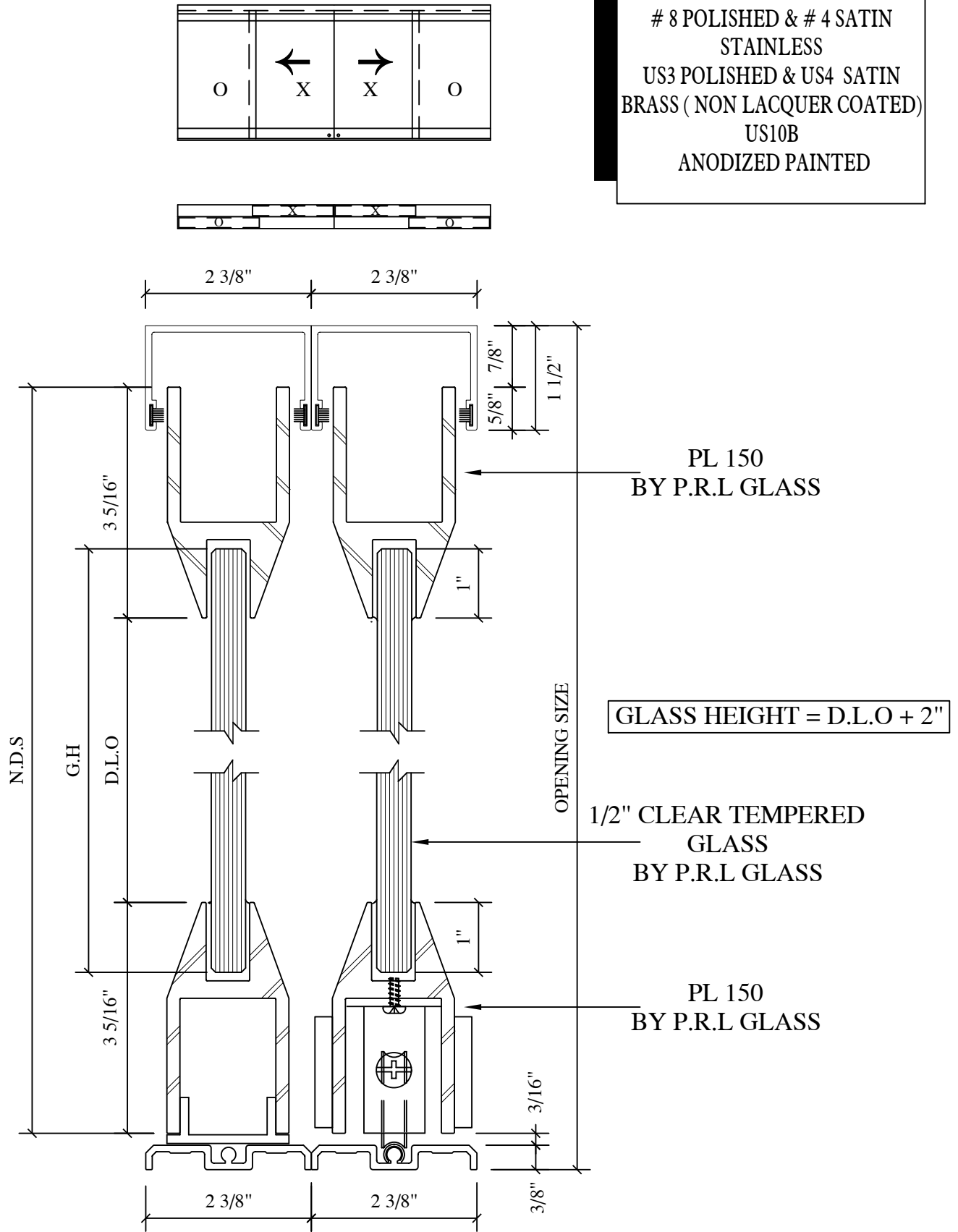

* FINISHES AVAILABLE :
8 POLISHED & # 4 SATIN STAINLESS
US3 POLISHED & US4 SATIN BRASS (NON LACQUER COATED)
US10B
ANODIZED PAINTED

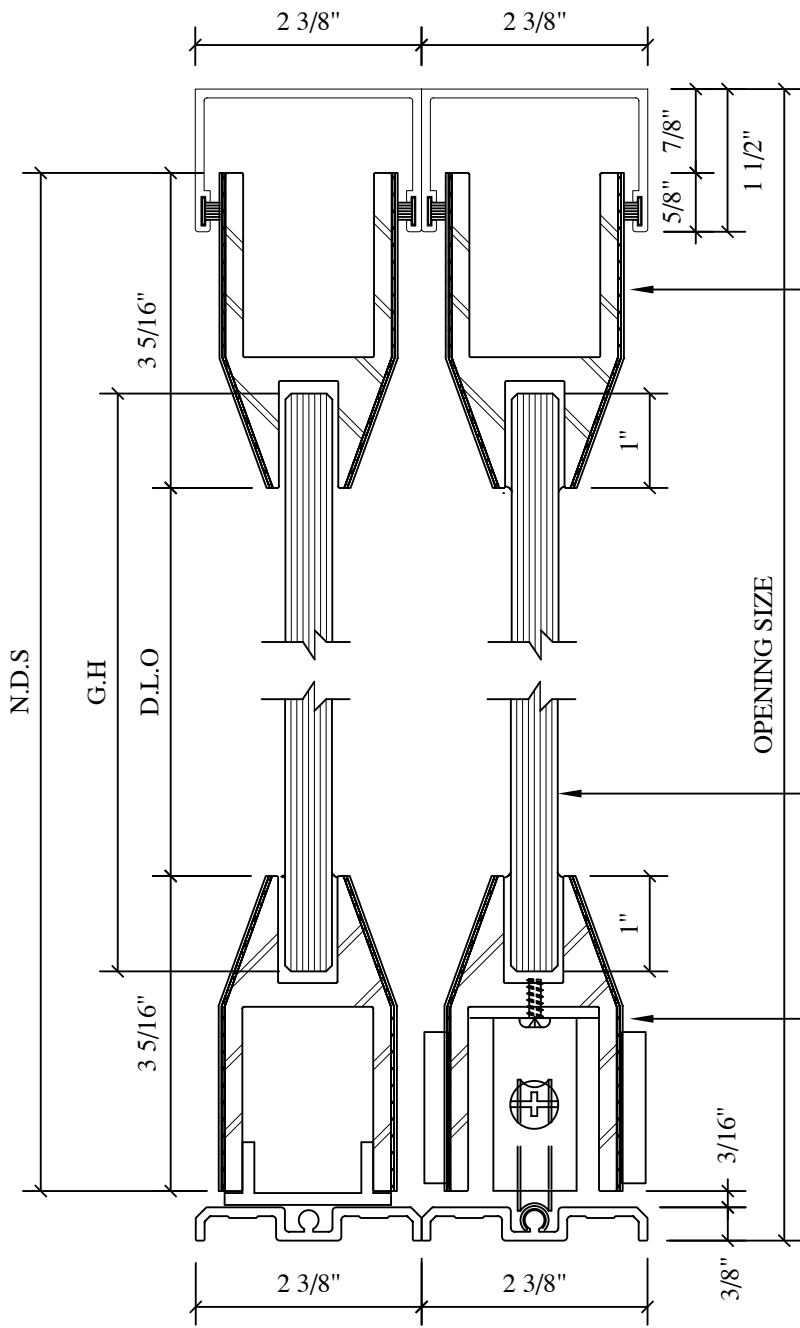
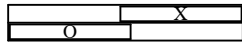
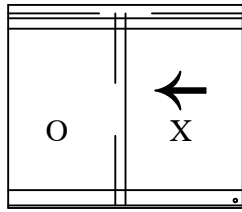

PL150 CLAD
BY P.R.L GLASS

GLASS HEIGHT = D.L.O + 2"

1/2" CLEAR TEMPERED
GLASS
BY P.R.L GLASS

PL 150 CLAD
BY P.R.L GLASS

* FINISHES AVAILABLE :
8 POLISHED & # 4 SATIN
STAINLESS
US3 POLISHED & US4 SATIN
BRASS (NON LACQUER COATED)
US10B
ANODIZED PAINTED

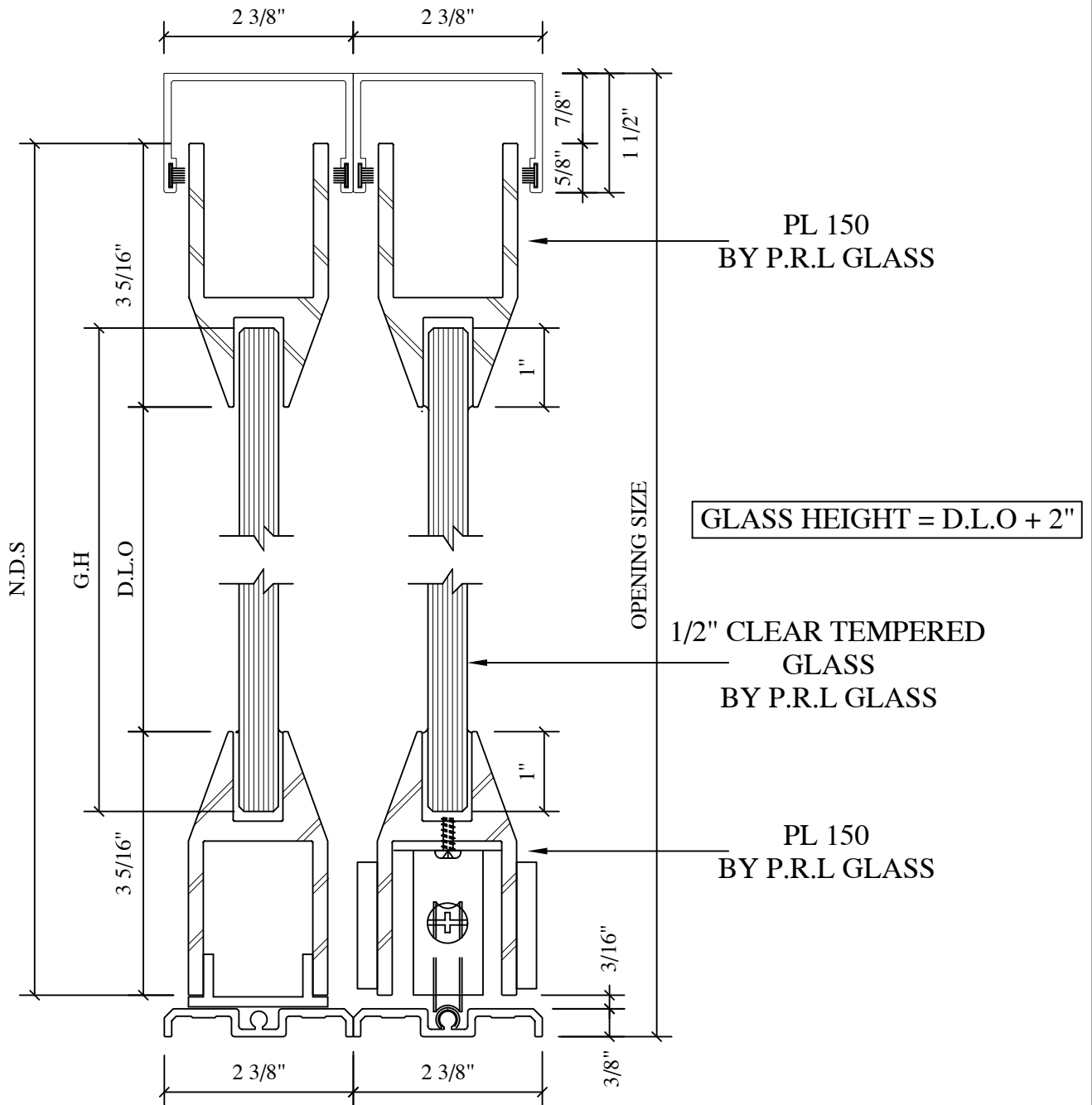
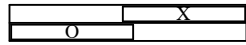
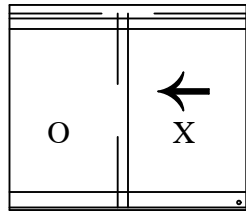

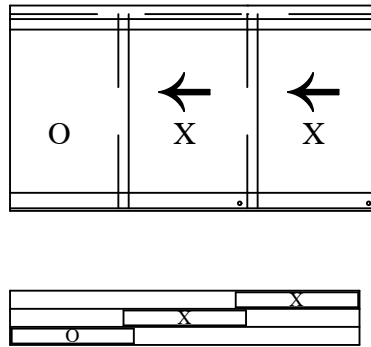

* FINISHES AVAILABLE :
8 POLISHED & # 4 SATIN
STAINLESS
US3 POLISHED & US4 SATIN
BRASS (NON LACQUER COATED)
US10B
ANODIZED PAINTED

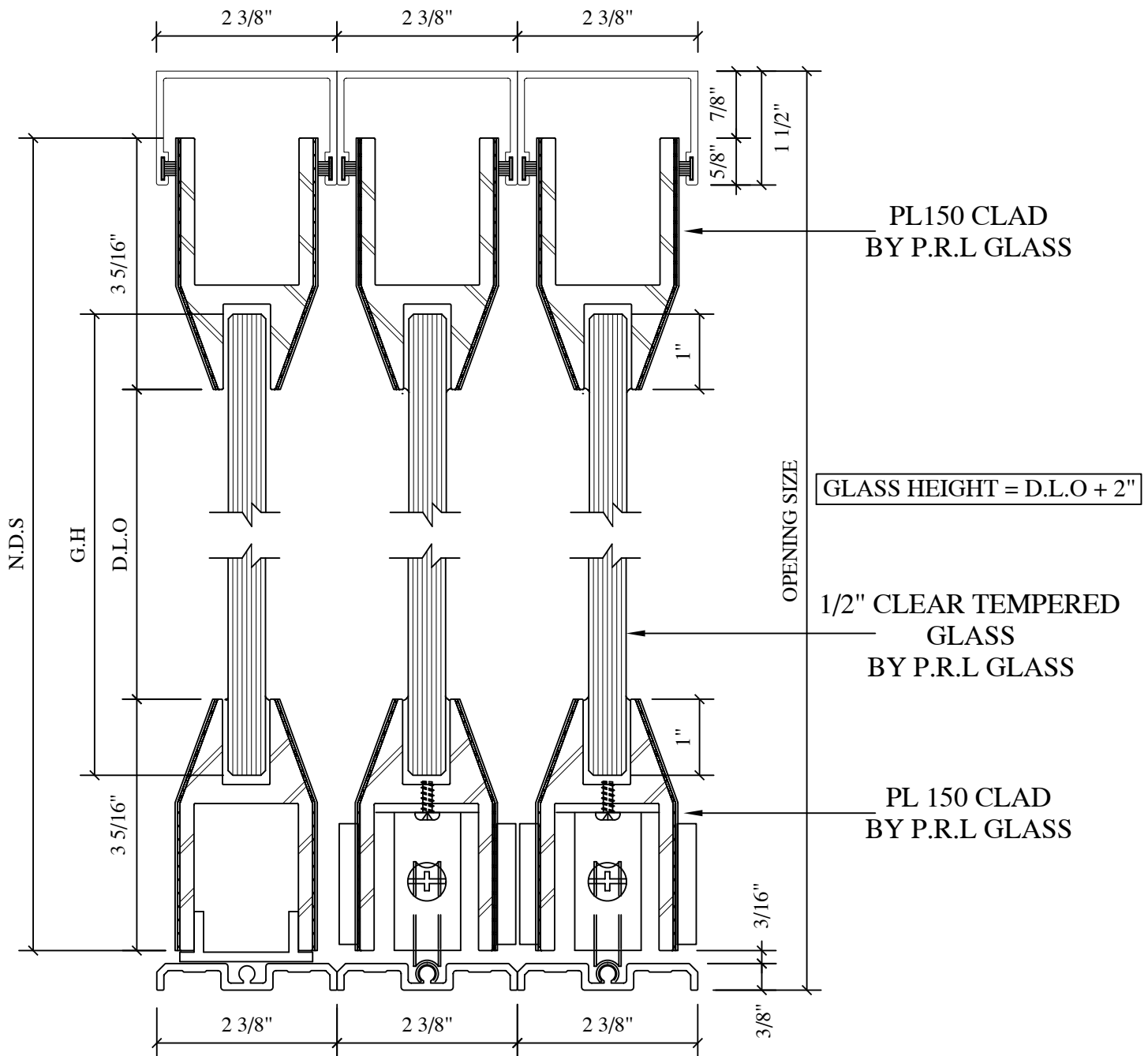

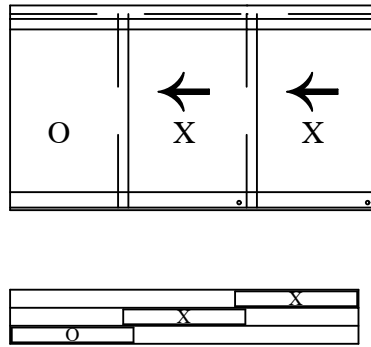

* FINISHES AVAILABLE :
8 POLISHED & # 4 SATIN
STAINLESS
US3 POLISHED & US4 SATIN
BRASS (NON LACQUER COATED)
US10B
ANODIZED PAINTED

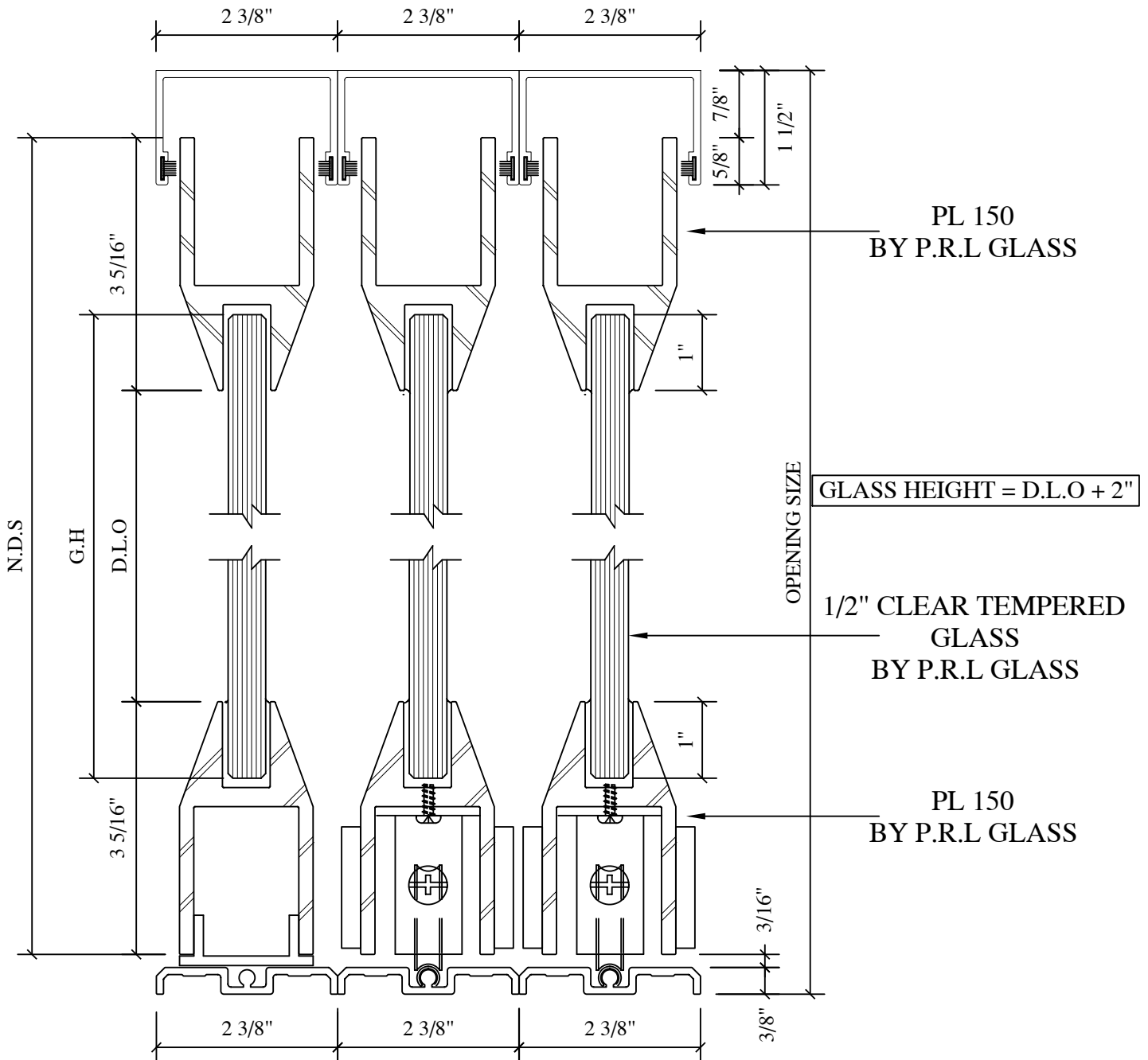

PRL

GLASS
SYSTEMS
INC.
PrIglass.com



PL150 CLAD BTM ROLL SYSTEM (X)

DWG NO.: BOTTOM ROLLING SLIDER1

DATE: 05/22/10

* FINISHES AVAILABLE :
8 POLISHED & # 4 SATIN
STAINLESS
US3 POLISHED & US4 SATIN
BRASS (NON LACQUER COATED)
US10B
ANODIZED PAINTED

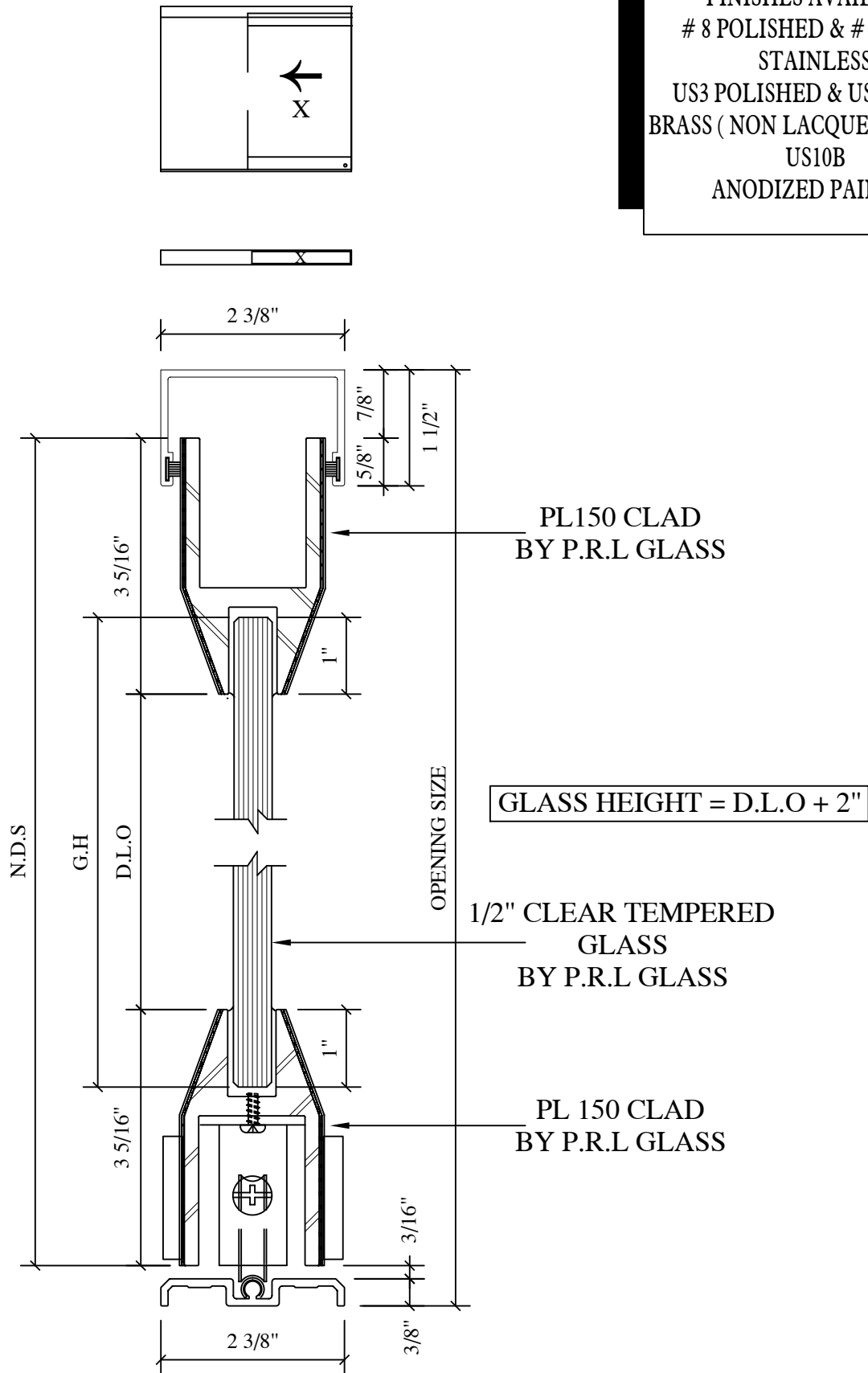

* FINISHES AVAILABLE :
8 POLISHED & # 4 SATIN
STAINLESS
US3 POLISHED & US4 SATIN
BRASS (NON LACQUER COATED)
US10B
ANODIZED PAINTED

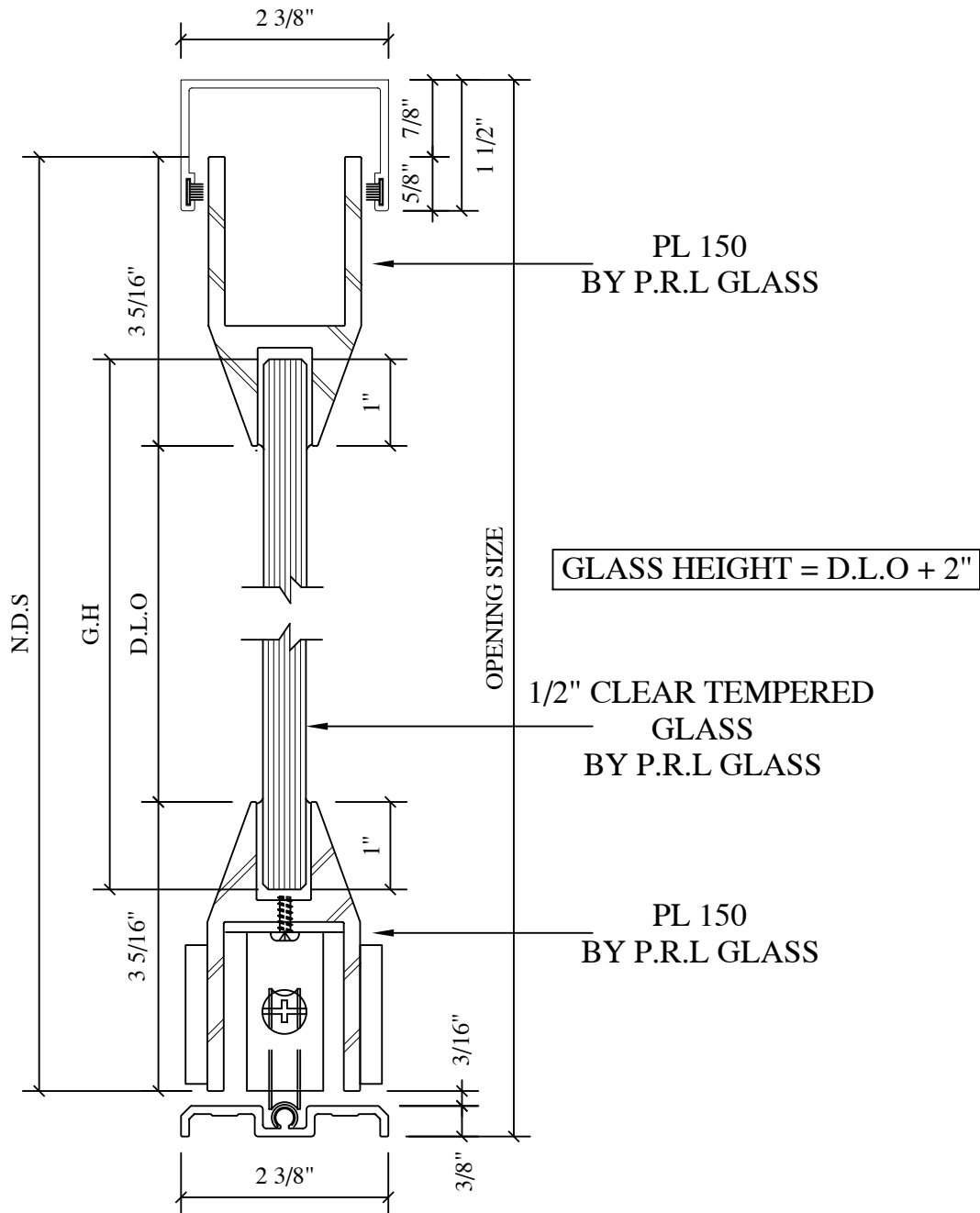
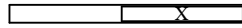
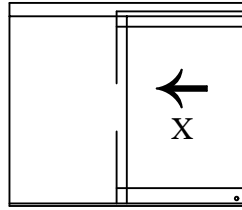

* FINISHES AVAILABLE :
8 POLISHED & # 4 SATIN
STAINLESS
US3 POLISHED & US4 SATIN
BRASS (NON LACQUER COATED)
US10B
ANODIZED PAINTED

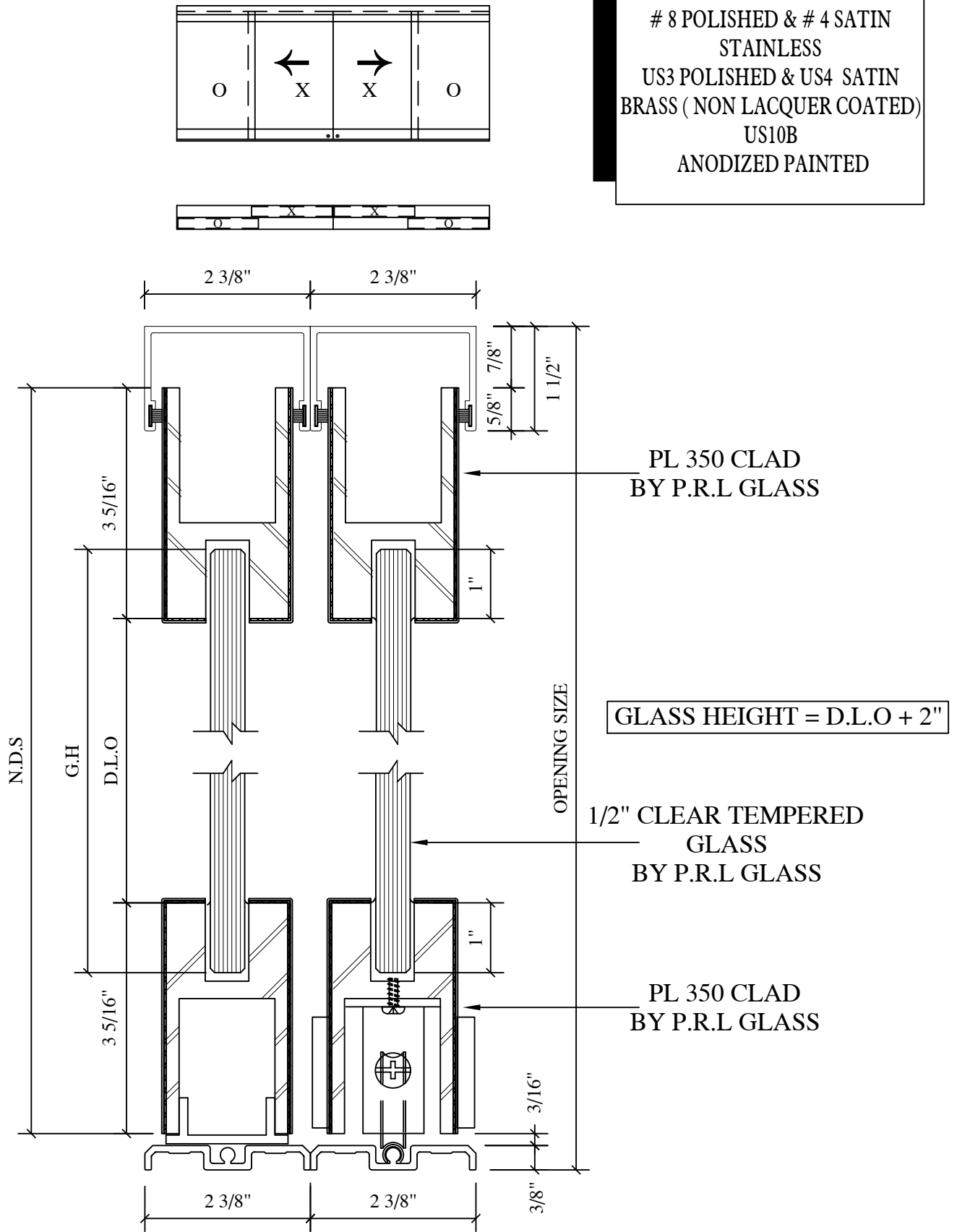

* FINISHES AVAILABLE :
 # 8 POLISHED & # 4 SATIN STAINLESS
 US3 POLISHED & US4 SATIN BRASS (NON LACQUER COATED)
 US10B
 ANODIZED PAINTED

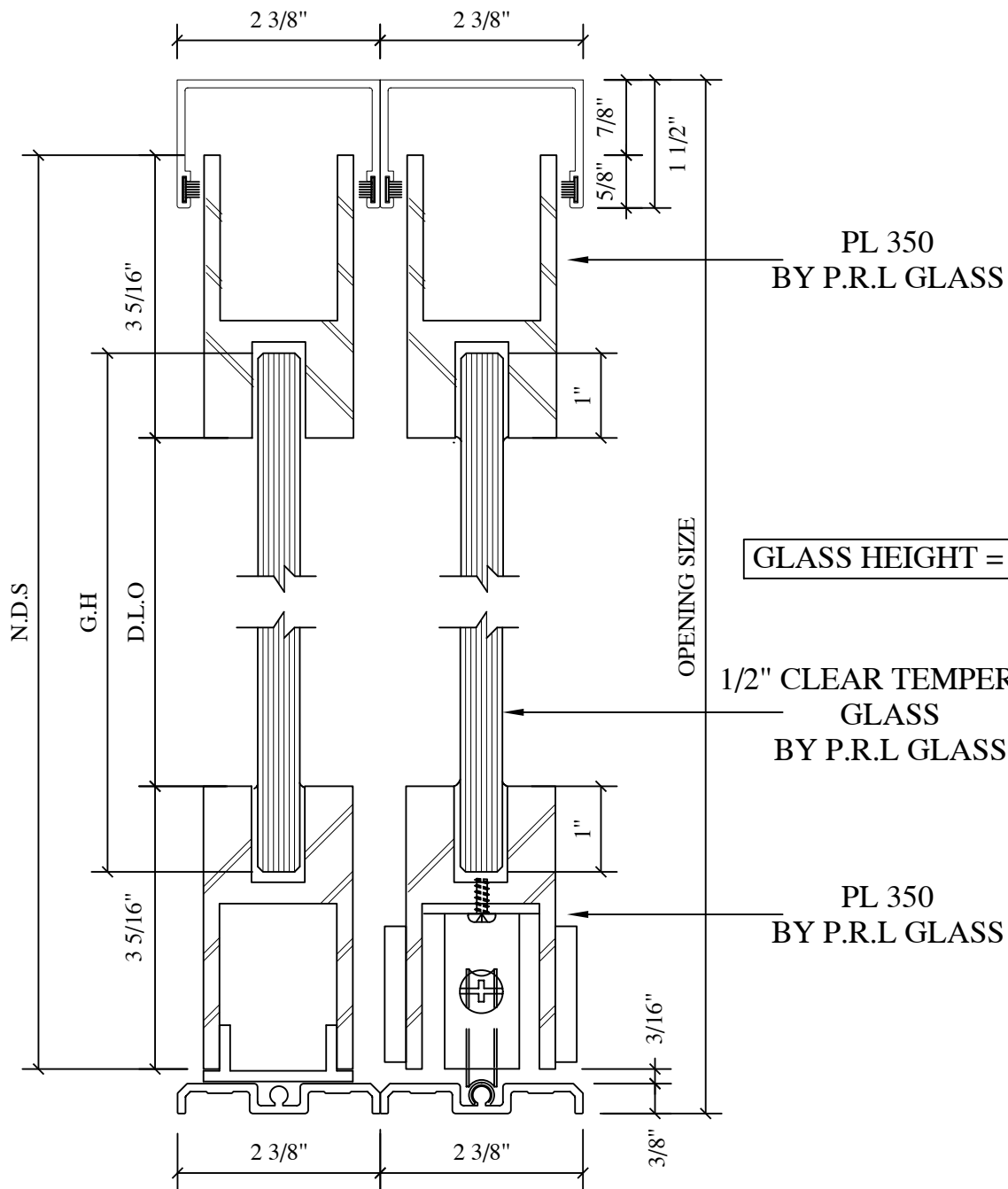
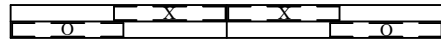
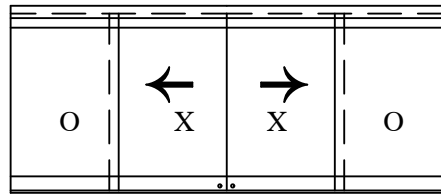

GLASS HEIGHT = D.L.O + 2"

* FINISHES AVAILABLE :
8 POLISHED & # 4 SATIN
STAINLESS
US3 POLISHED & US4 SATIN
BRASS (NON LACQUER COATED)
US10B
ANODIZED PAINTED

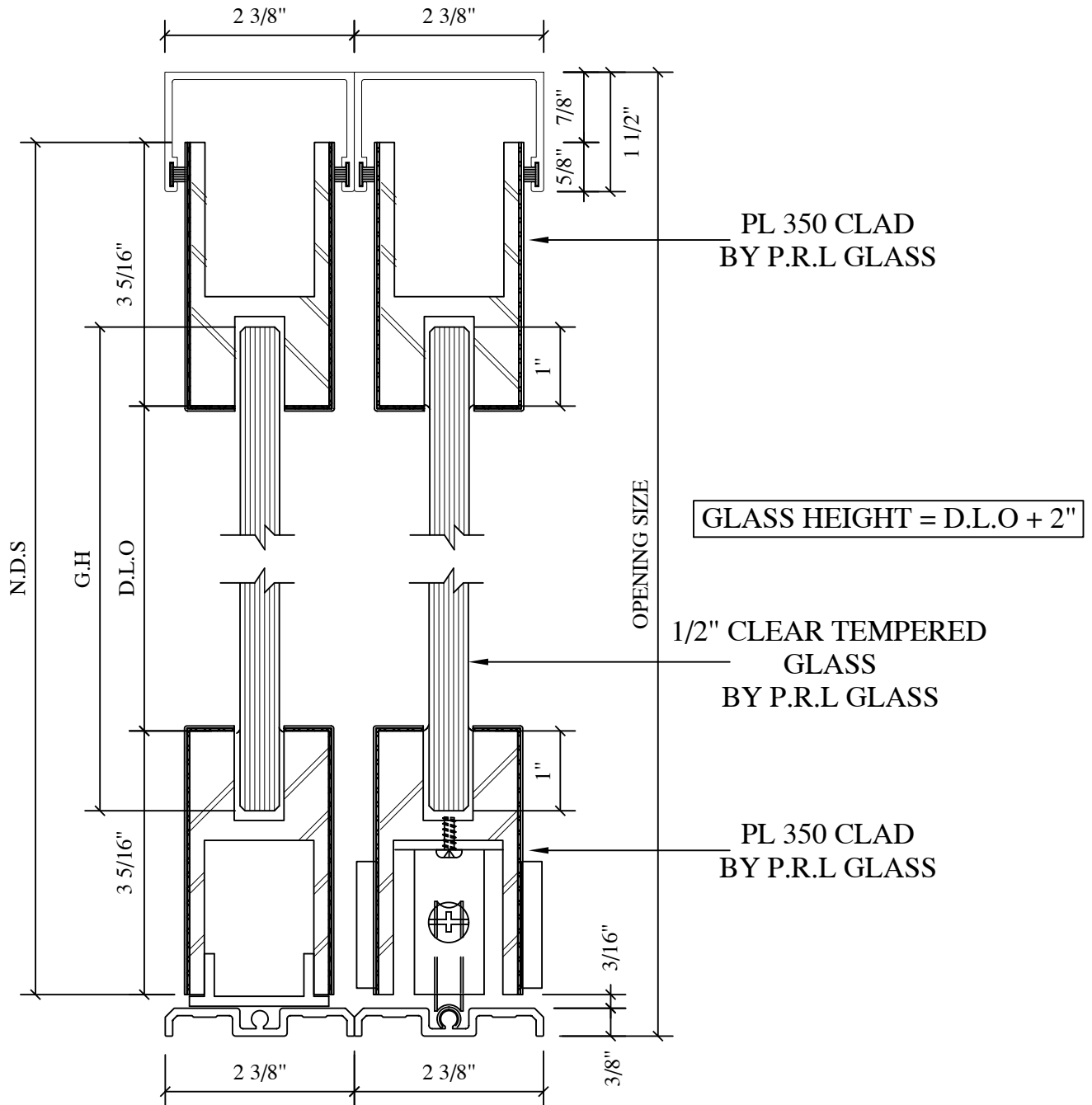
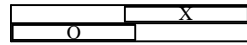
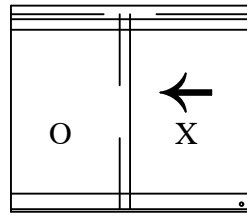

* FINISHES AVAILABLE :
8 POLISHED & # 4 SATIN
STAINLESS
US3 POLISHED & US4 SATIN
BRASS (NON LACQUER COATED)
US10B
ANODIZED PAINTED

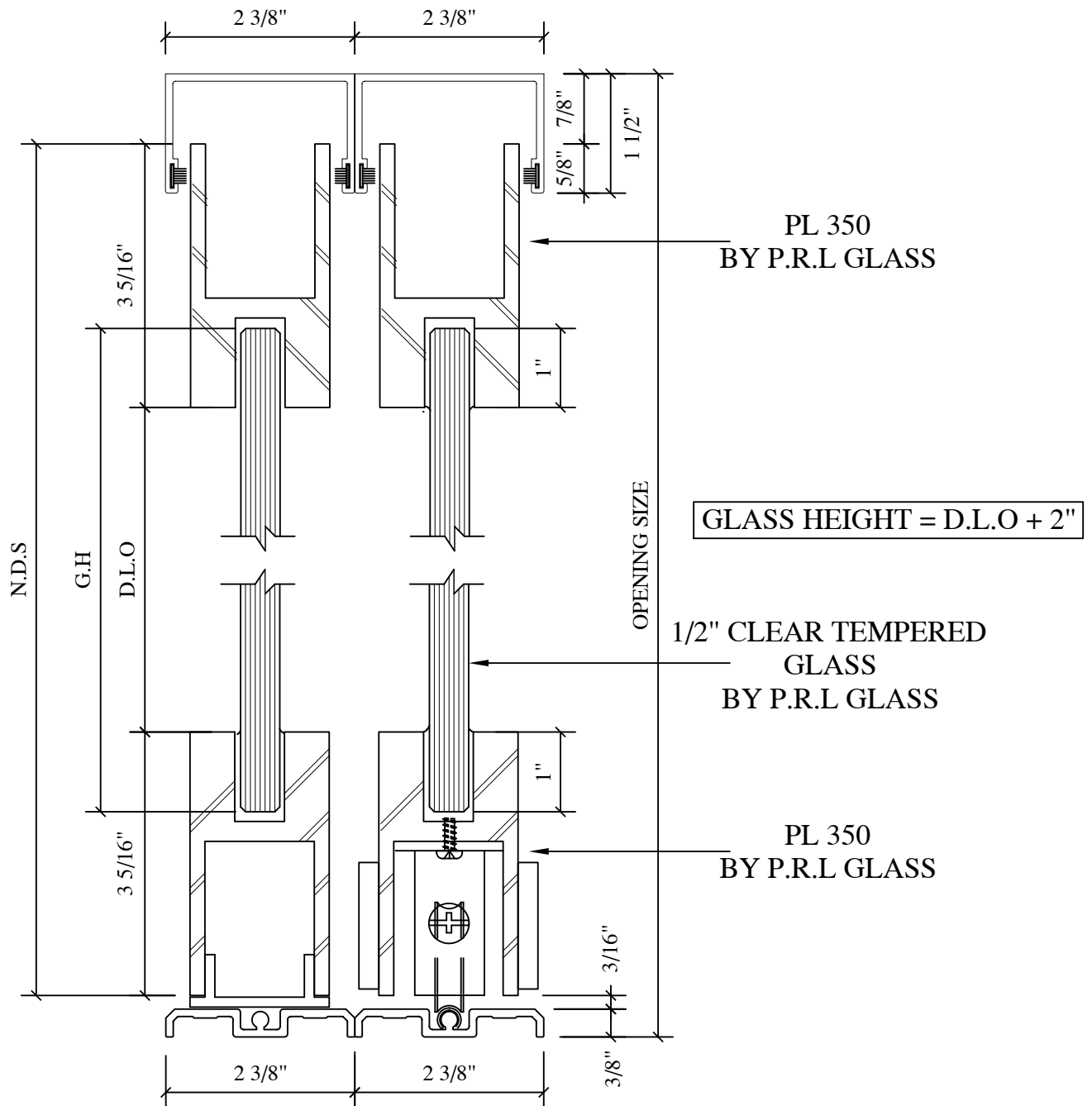
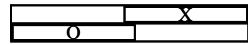
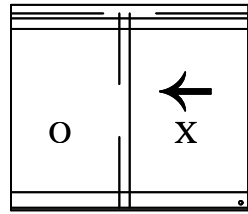

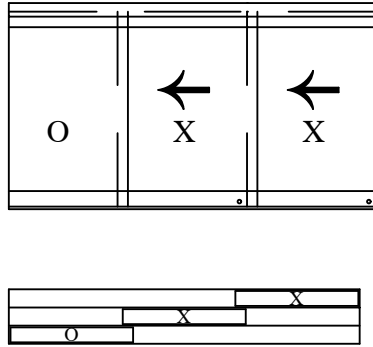

* FINISHES AVAILABLE :
8 POLISHED & # 4 SATIN
STAINLESS
US3 POLISHED & US4 SATIN
BRASS (NON LACQUER COATED)
US10B
ANODIZED PAINTED

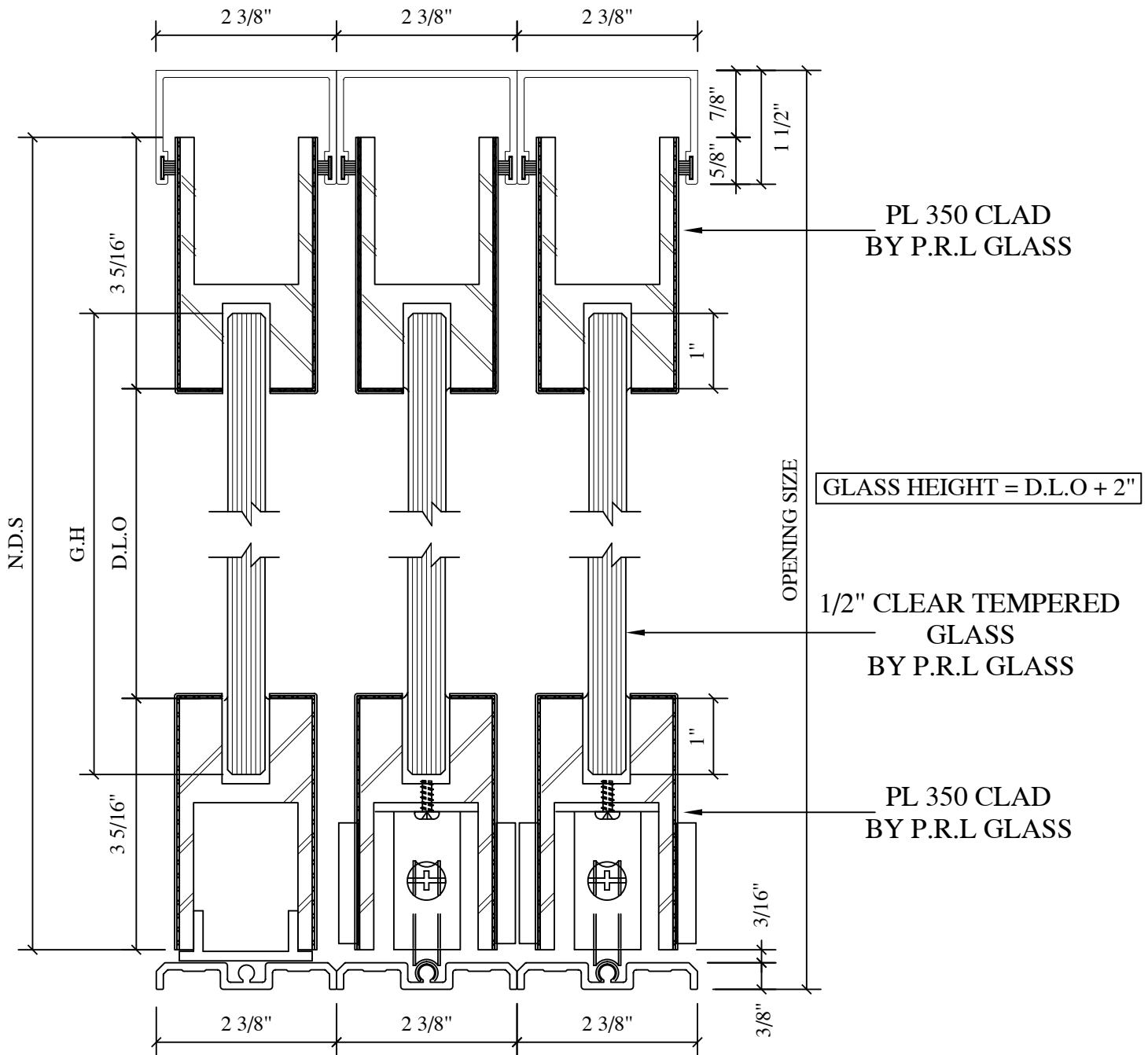

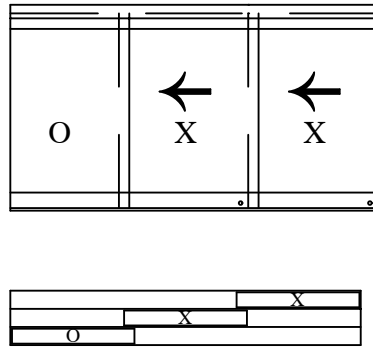

* FINISHES AVAILABLE :
8 POLISHED & # 4 SATIN
STAINLESS
US3 POLISHED & US4 SATIN
BRASS (NON LACQUER COATED)
US10B
ANODIZED PAINTED

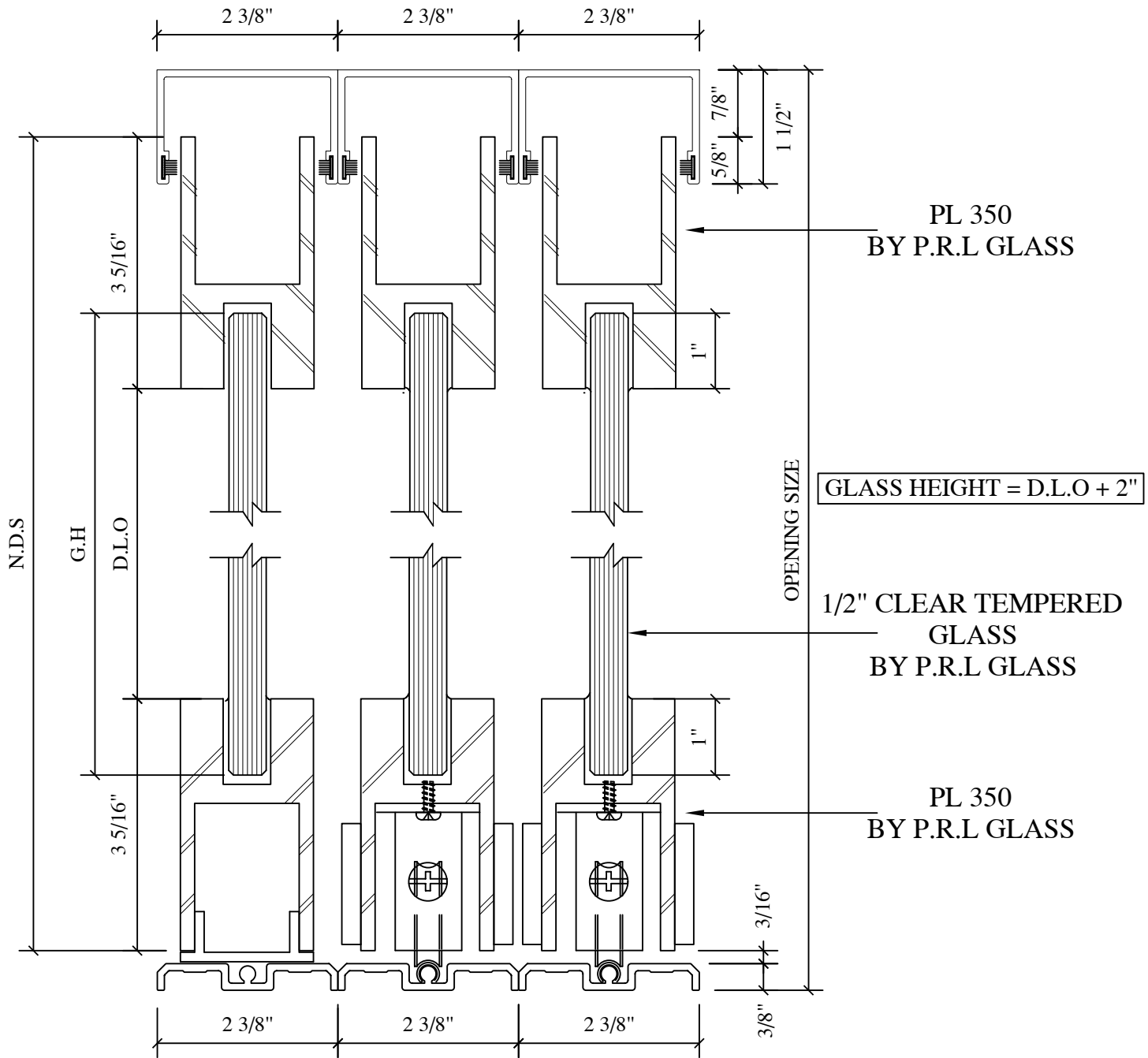

* FINISHES AVAILABLE :
8 POLISHED & # 4 SATIN
STAINLESS
US3 POLISHED & US4 SATIN
BRASS (NON LACQUER COATED)
US10B
ANODIZED PAINTED

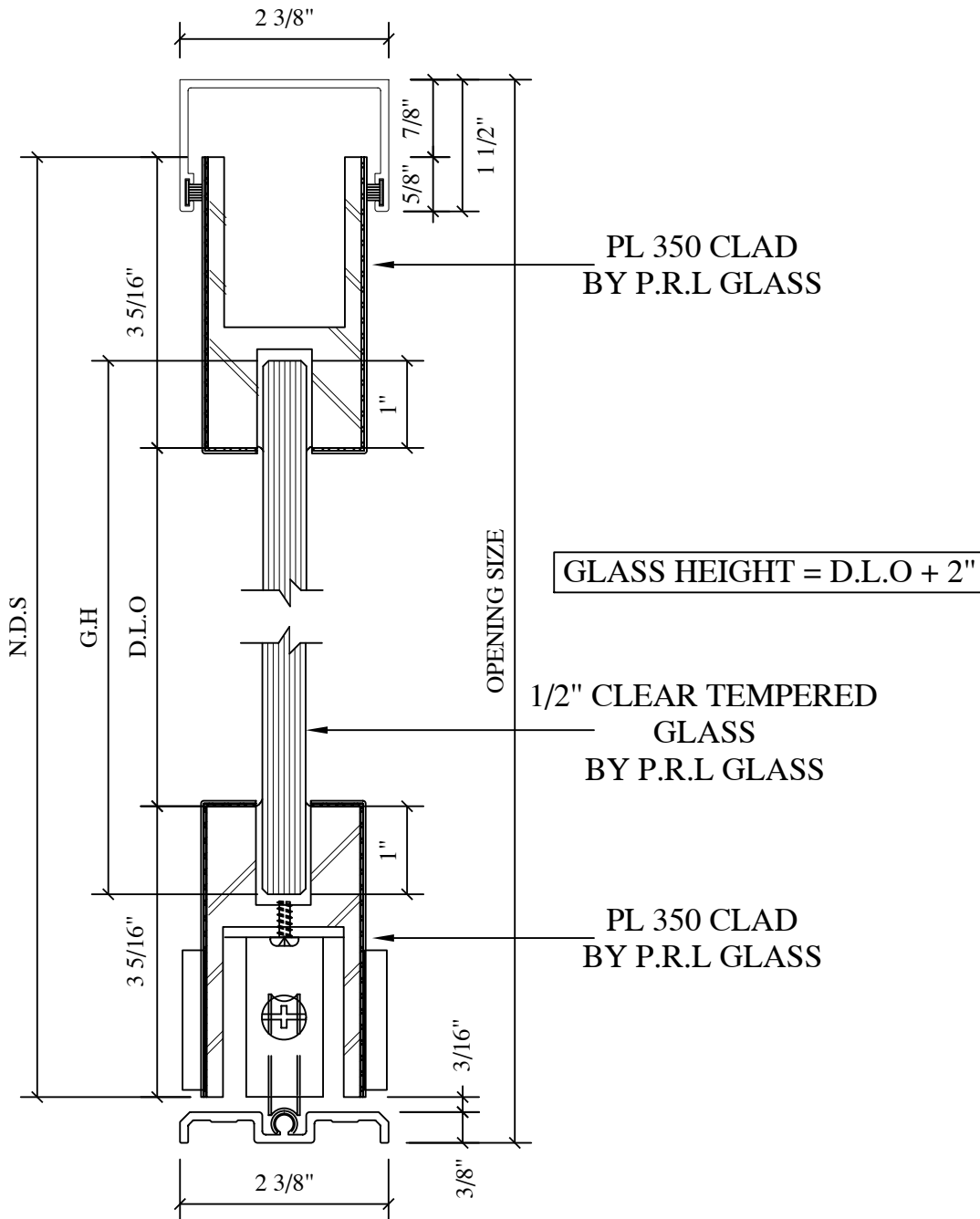
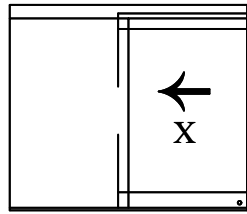

* FINISHES AVAILABLE :
8 POLISHED & # 4 SATIN
STAINLESS
US3 POLISHED & US4 SATIN
BRASS (NON LACQUER COATED)
US10B
ANODIZED PAINTED

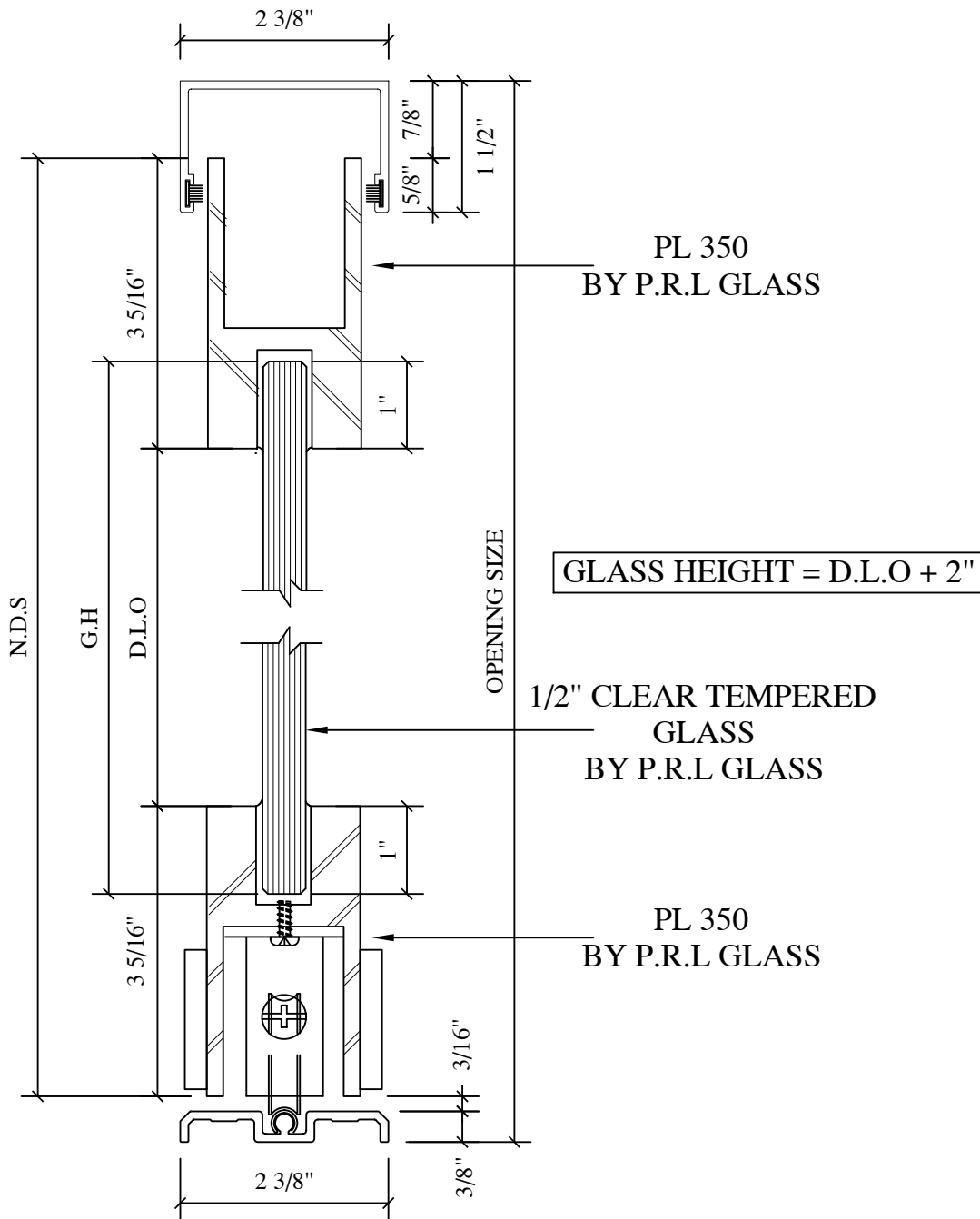
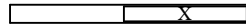
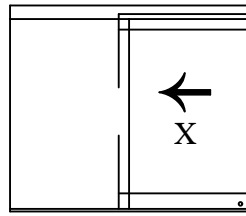

PRL

GLASS
SYSTEMS
INC.
PrIglass.com



PL175 CLAD BTM ROLL SYSTEM (O,X,X,O)

DWG NO.: BOTTOM ROLLING SLIDER1

DATE: 05/22/10

* FINISHES AVAILABLE :
8 POLISHED & # 4 SATIN
STAINLESS
US3 POLISHED & US4 SATIN
BRASS (NON LACQUER COATED)
US10B
ANODIZED PAINTED

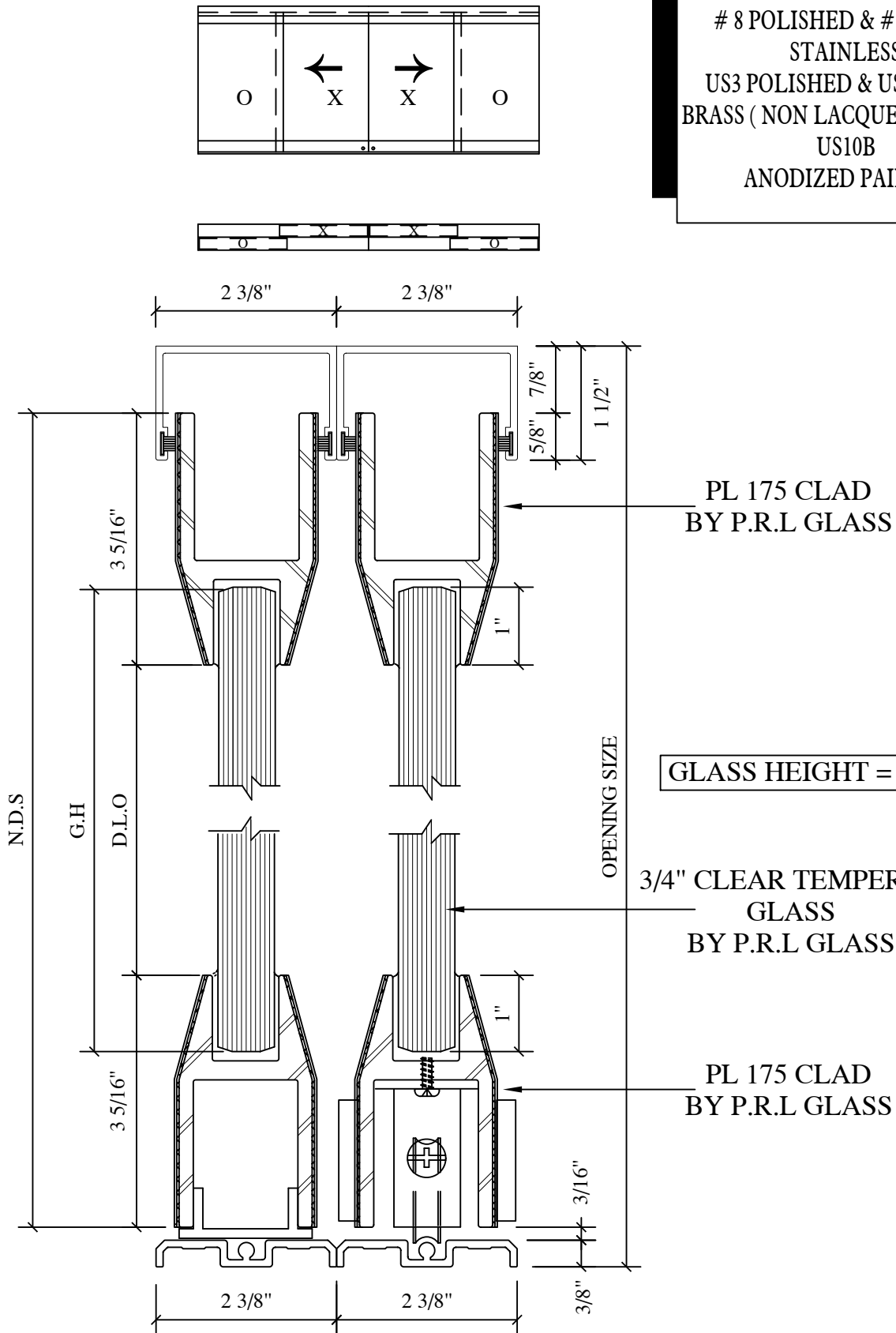

* FINISHES AVAILABLE :
8 POLISHED & # 4 SATIN
STAINLESS
US3 POLISHED & US4 SATIN
BRASS (NON LACQUER COATED)
US10B
ANODIZED PAINTED

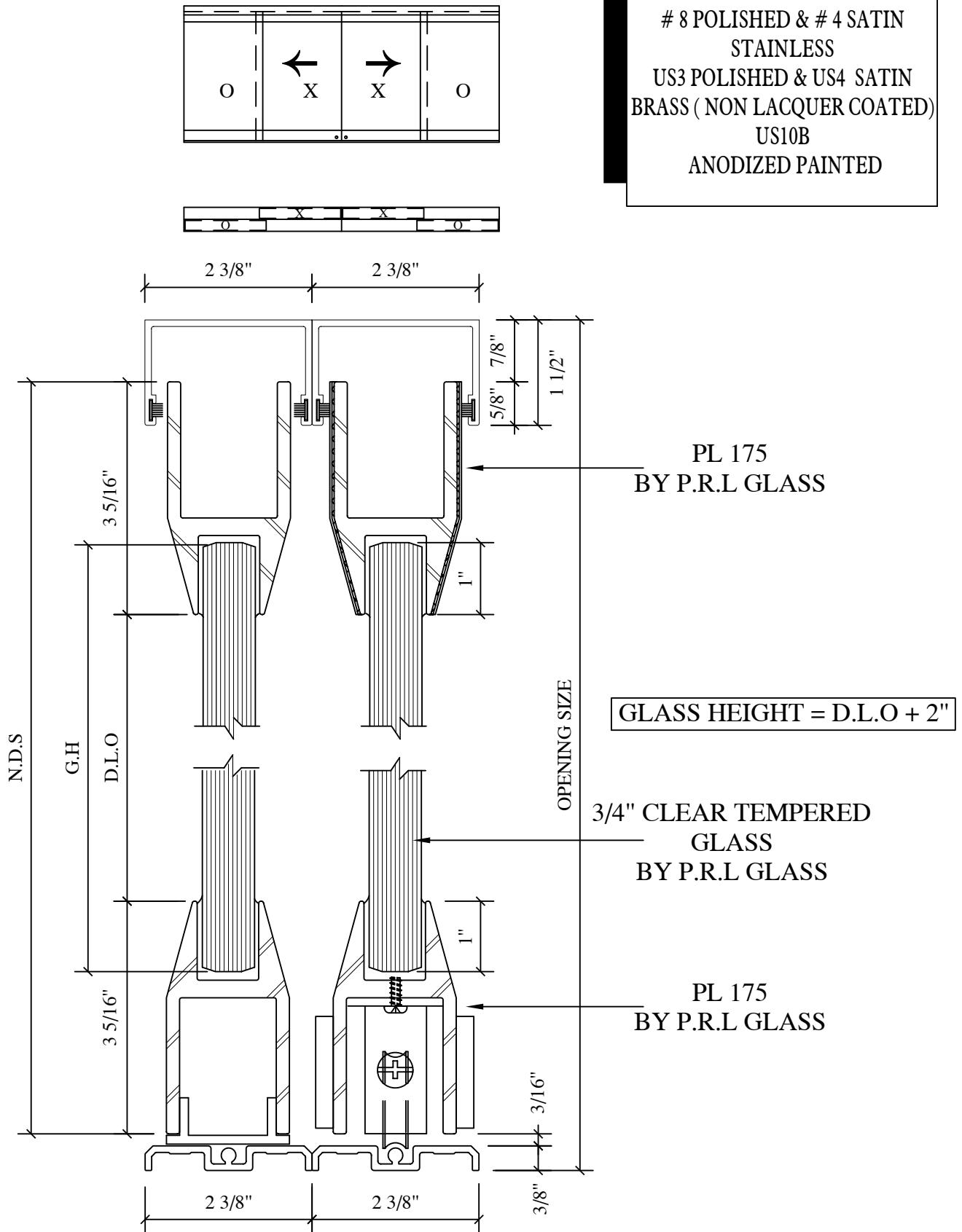

* FINISHES AVAILABLE :
8 POLISHED & # 4 SATIN
STAINLESS
US3 POLISHED & US4 SATIN
BRASS (NON LACQUER COATED)
US10B
ANODIZED PAINTED

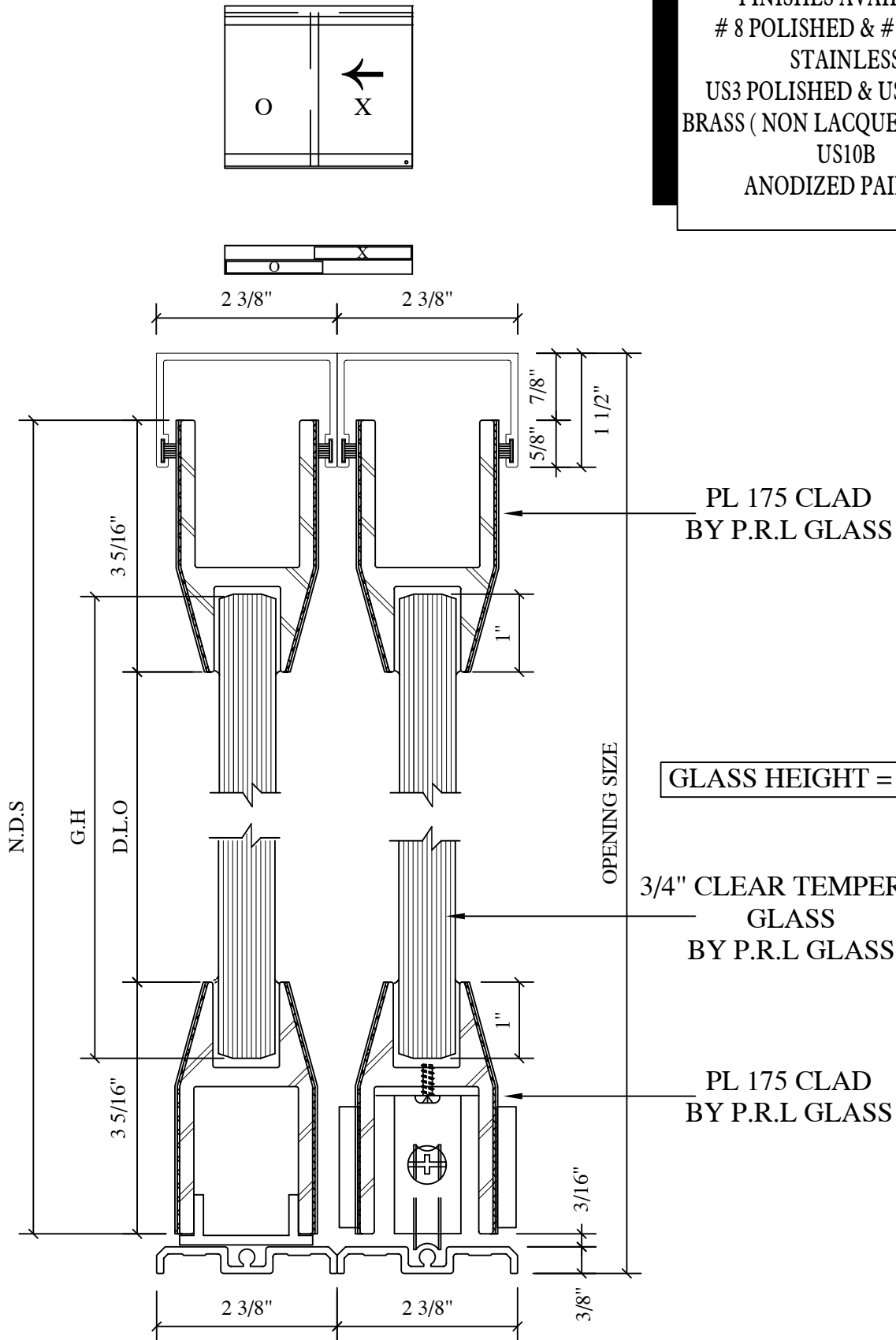

* FINISHES AVAILABLE :
8 POLISHED & # 4 SATIN
STAINLESS
US3 POLISHED & US4 SATIN
BRASS (NON LACQUER COATED)
US10B
ANODIZED PAINTED

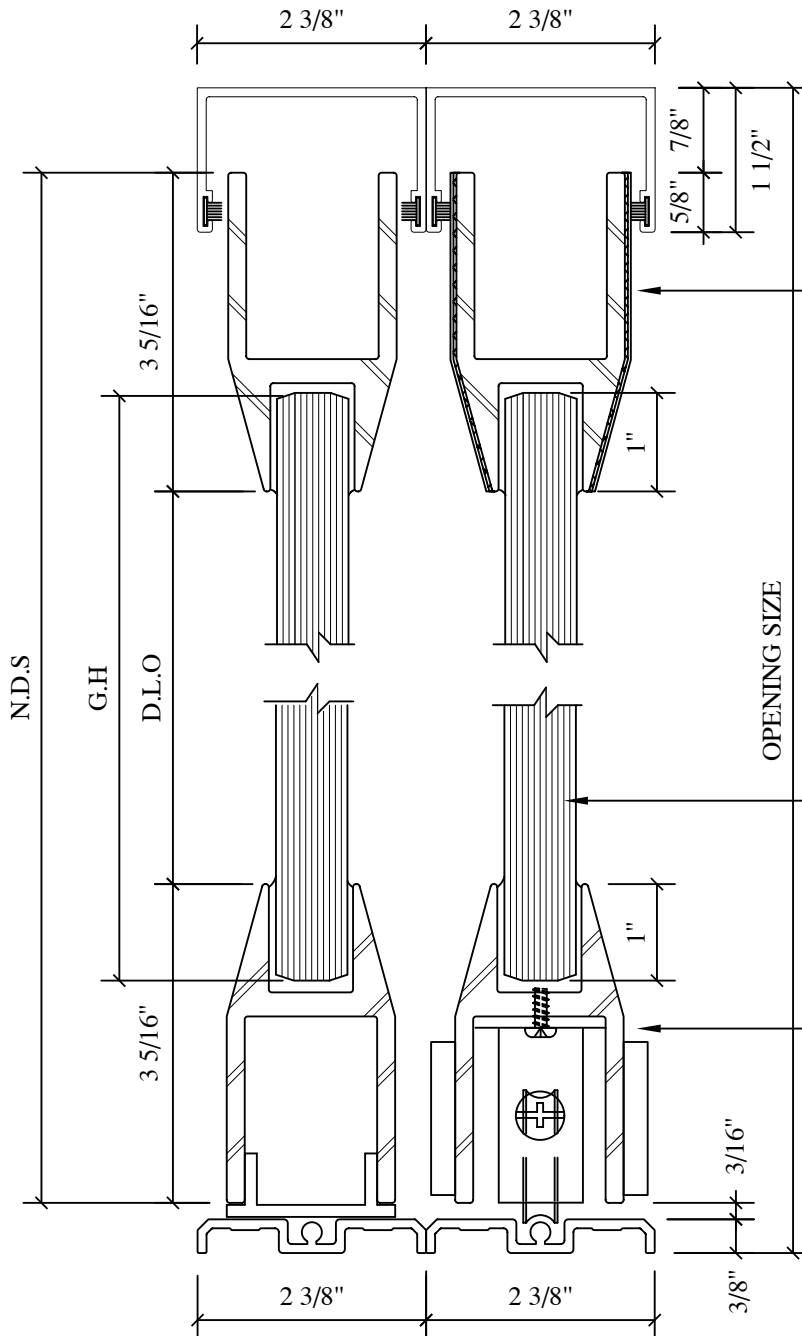
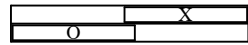
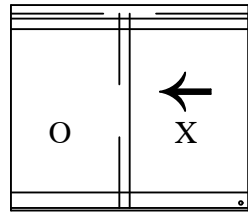

PL 175
BY P.R.L GLASS

GLASS HEIGHT = D.L.O + 2"

3/4" CLEAR TEMPERED
GLASS
BY P.R.L GLASS

PL 175
BY P.R.L GLASS

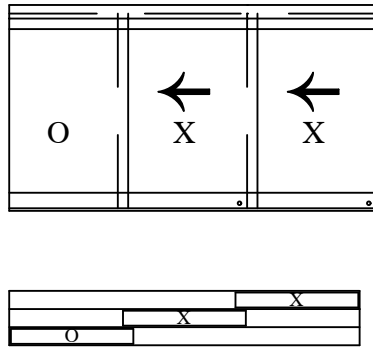

* FINISHES AVAILABLE :
8 POLISHED & # 4 SATIN
STAINLESS
US3 POLISHED & US4 SATIN
BRASS (NON LACQUER COATED)
US10B
ANODIZED PAINTED

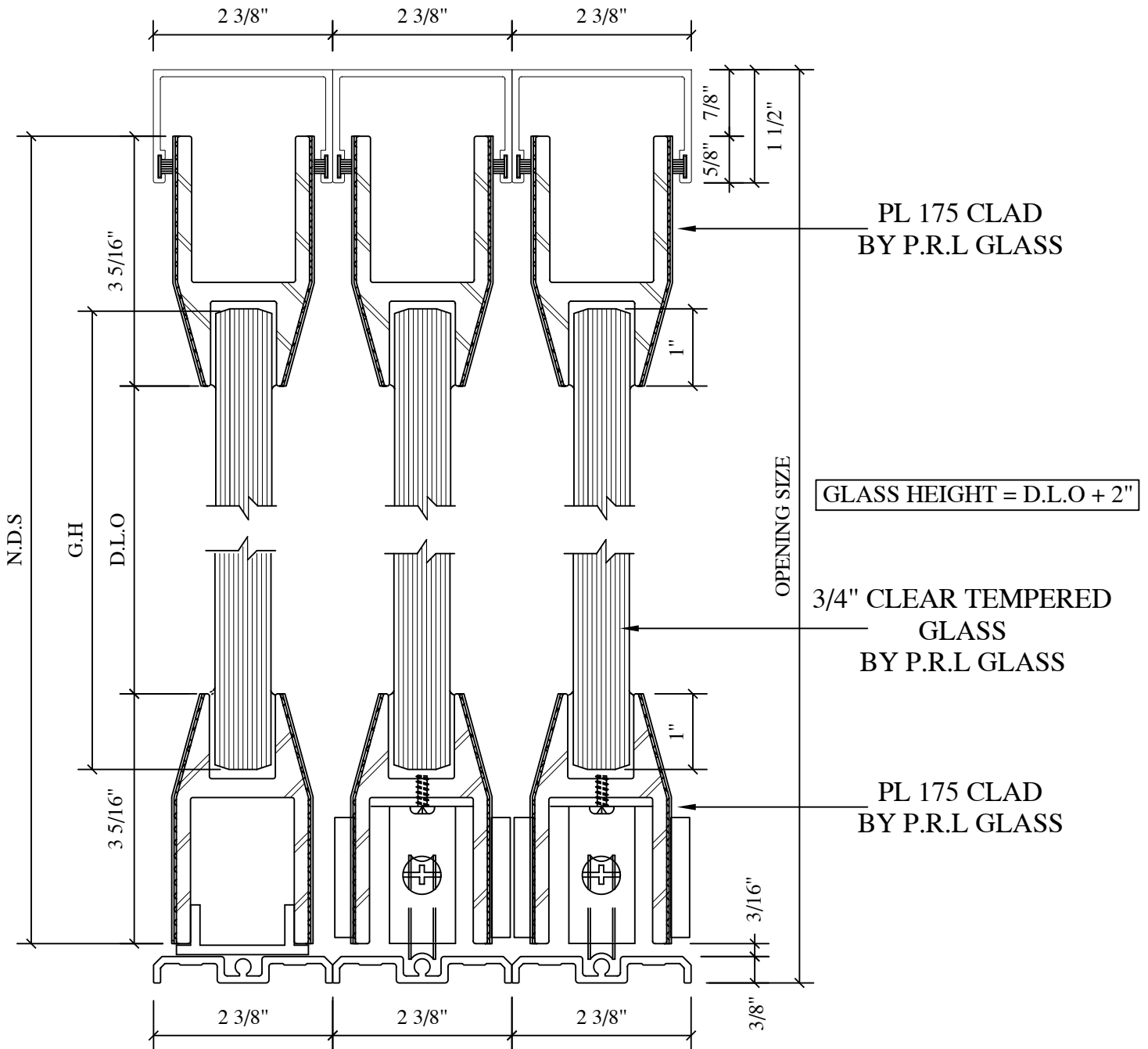

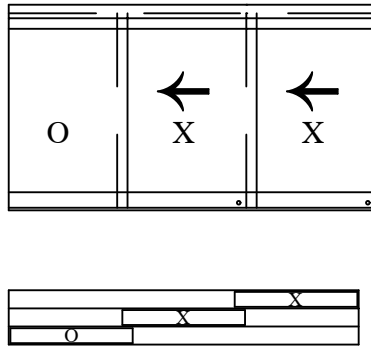

* FINISHES AVAILABLE :
8 POLISHED & # 4 SATIN
STAINLESS
US3 POLISHED & US4 SATIN
BRASS (NON LACQUER COATED)
US10B
ANODIZED PAINTED

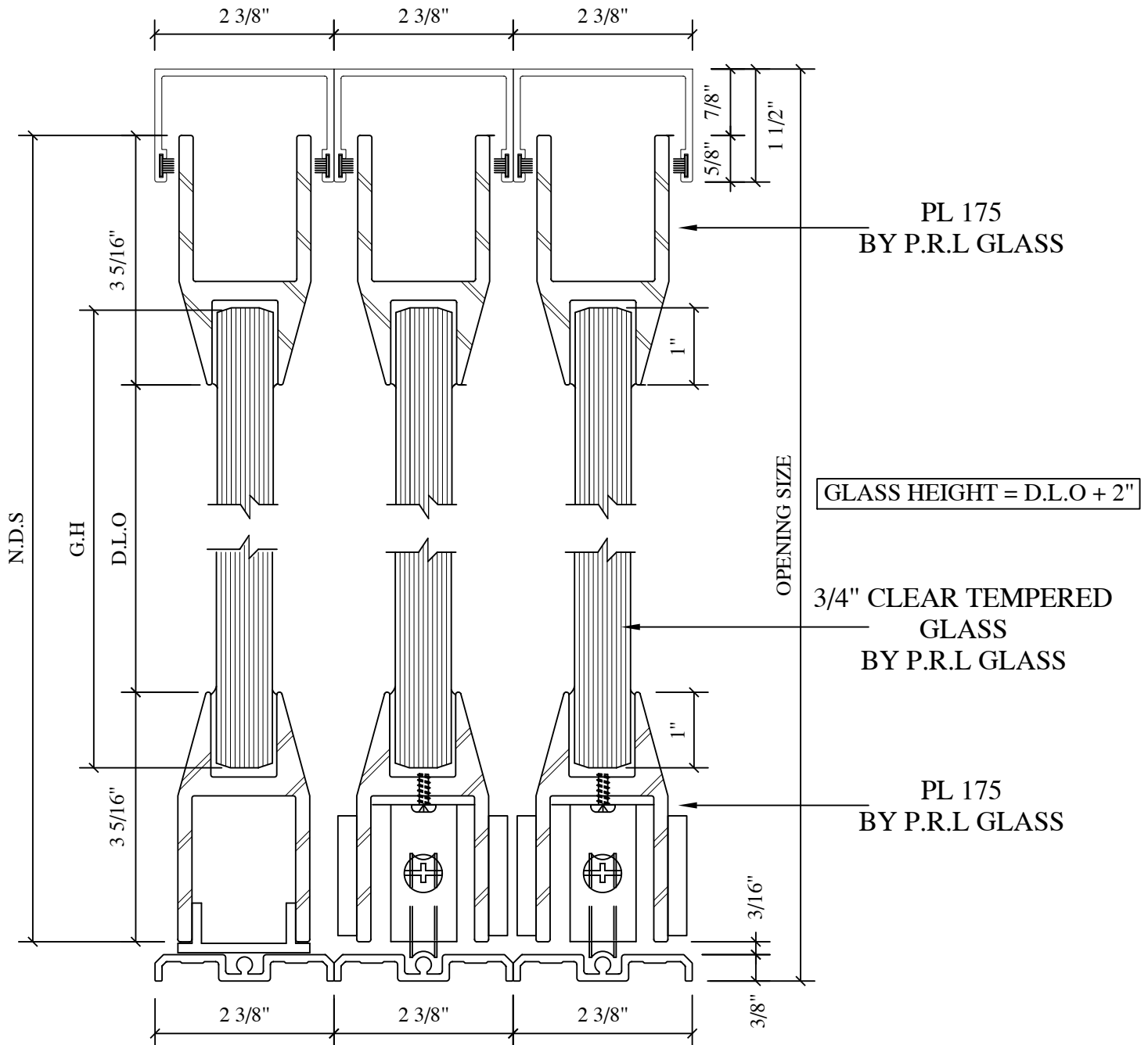

PRL

GLASS
SYSTEMS
INC.

Prlglass.com



PL175 CLAD BTM ROLL SYSTEM (X)

DWG NO.: BOTTOM ROLLING SLIDER1

DATE: 05/22/10

* FINISHES AVAILABLE :
8 POLISHED & # 4 SATIN
STAINLESS
US3 POLISHED & US4 SATIN
BRASS (NON LACQUER COATED)
US10B
ANODIZED PAINTED

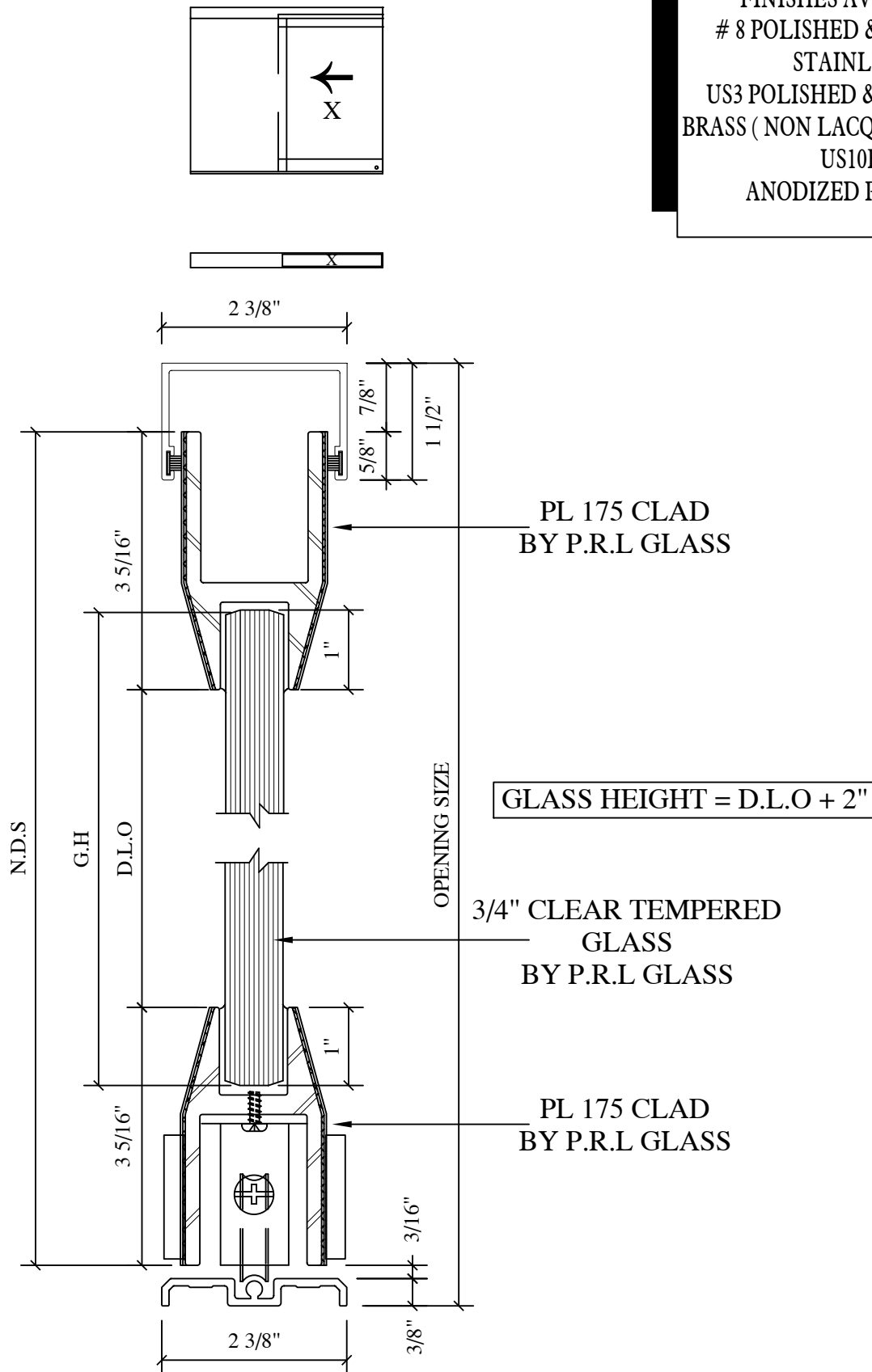

* FINISHES AVAILABLE :
8 POLISHED & # 4 SATIN
STAINLESS
US3 POLISHED & US4 SATIN
BRASS (NON LACQUER COATED)
US10B
ANODIZED PAINTED

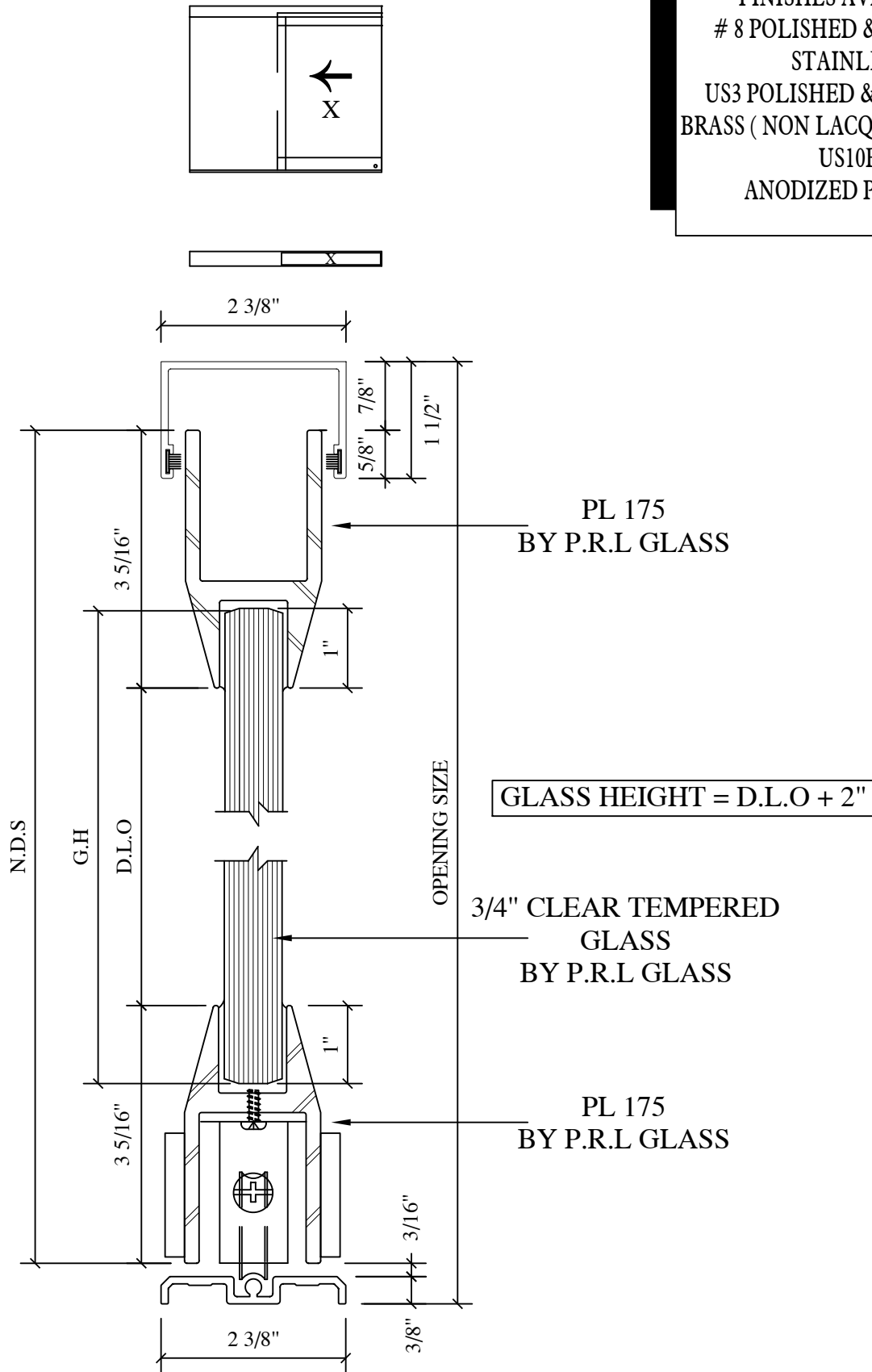

* FINISHES AVAILABLE :
8 POLISHED & # 4 SATIN
STAINLESS
US3 POLISHED & US4 SATIN
BRASS (NON LACQUER COATED)
US10B
ANODIZED PAINTED

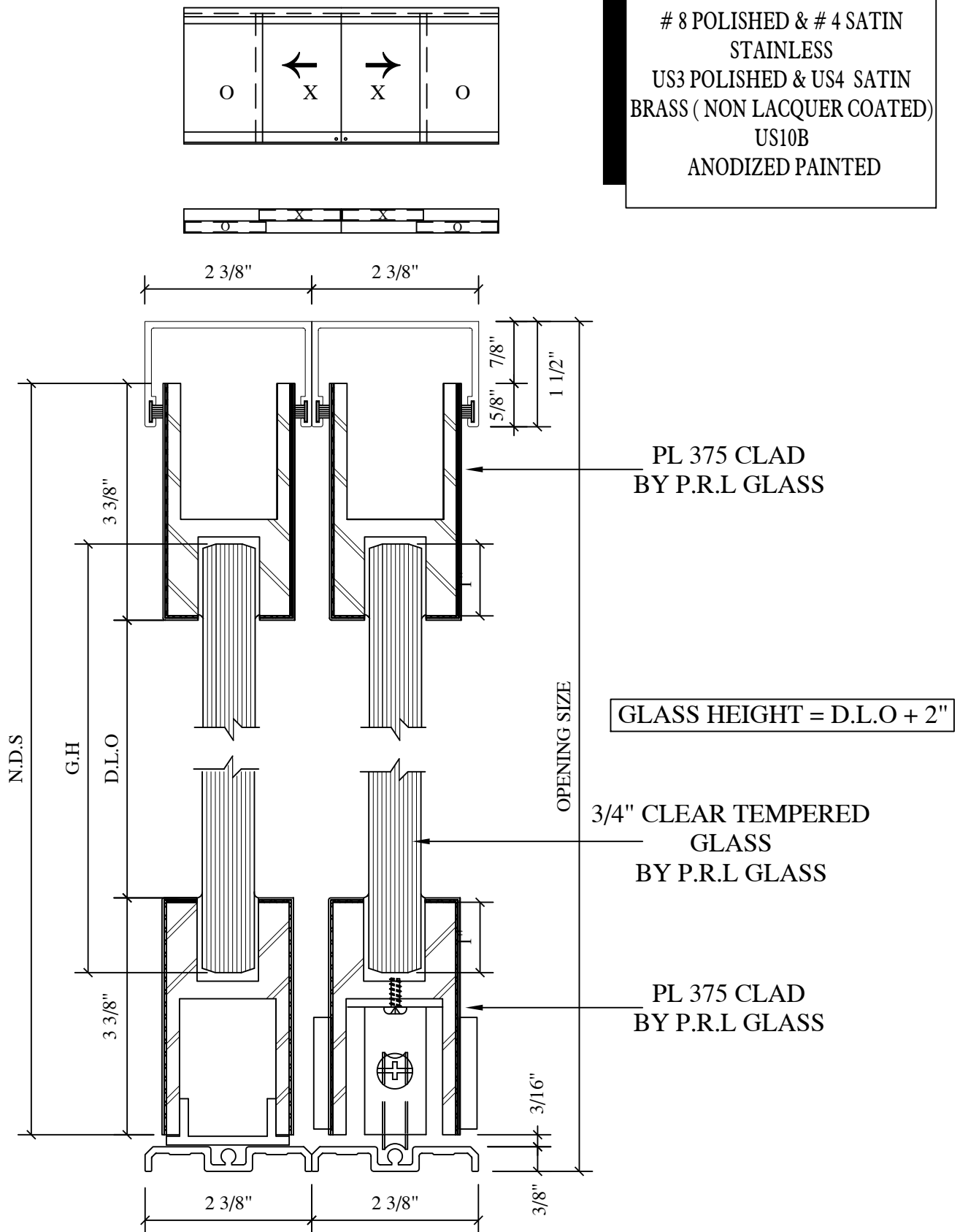

* FINISHES AVAILABLE :
8 POLISHED & # 4 SATIN
STAINLESS
US3 POLISHED & US4 SATIN
BRASS (NON LACQUER COATED)
US10B
ANODIZED PAINTED

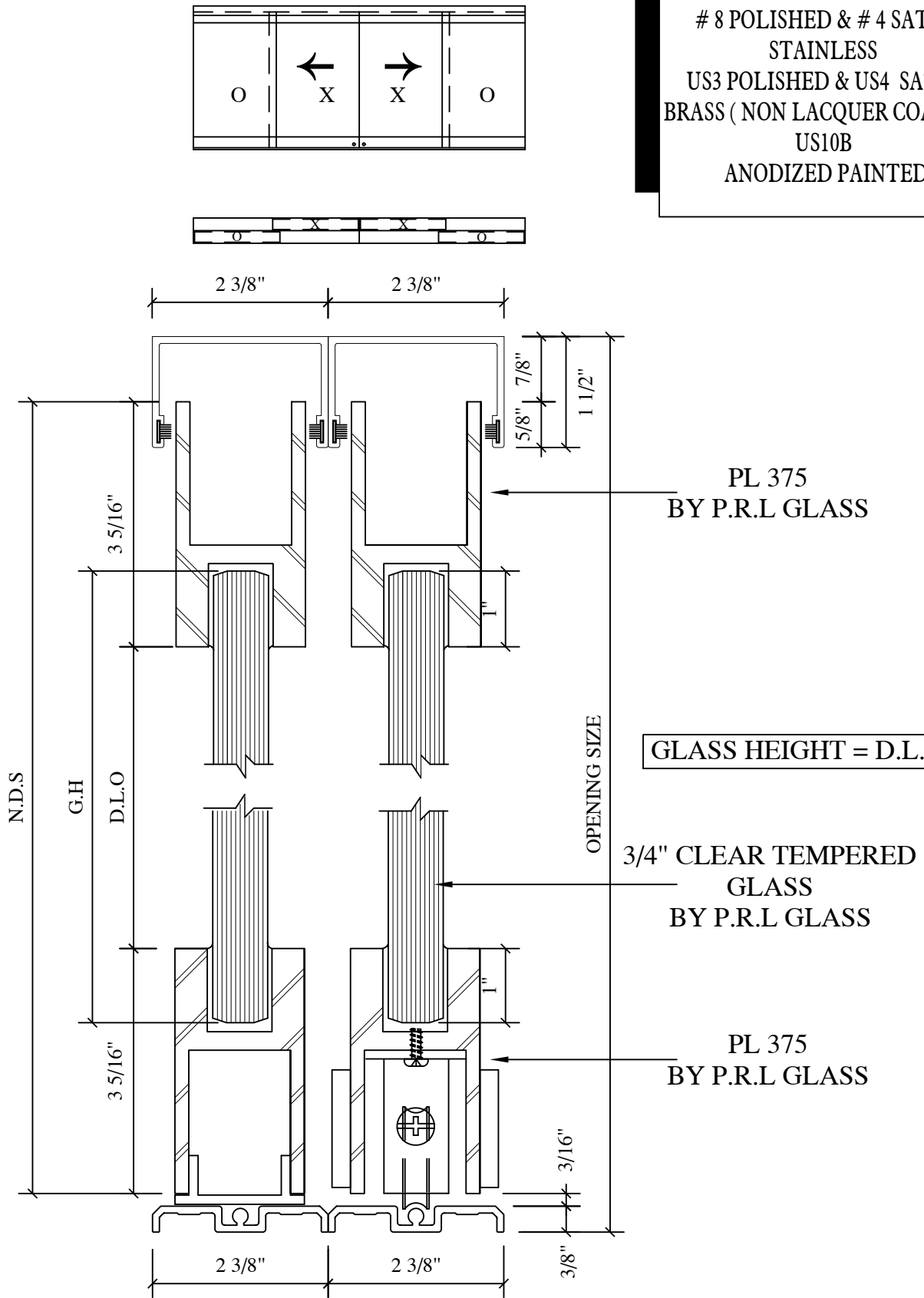

PL 375
BY P.R.L GLASS

GLASS HEIGHT = D.L.O + 2"

3/4" CLEAR TEMPERED
GLASS
BY P.R.L GLASS

PL 375
BY P.R.L GLASS

* FINISHES AVAILABLE :
8 POLISHED & # 4 SATIN
STAINLESS
US3 POLISHED & US4 SATIN
BRASS (NON LACQUER COATED)
US10B
ANODIZED PAINTED

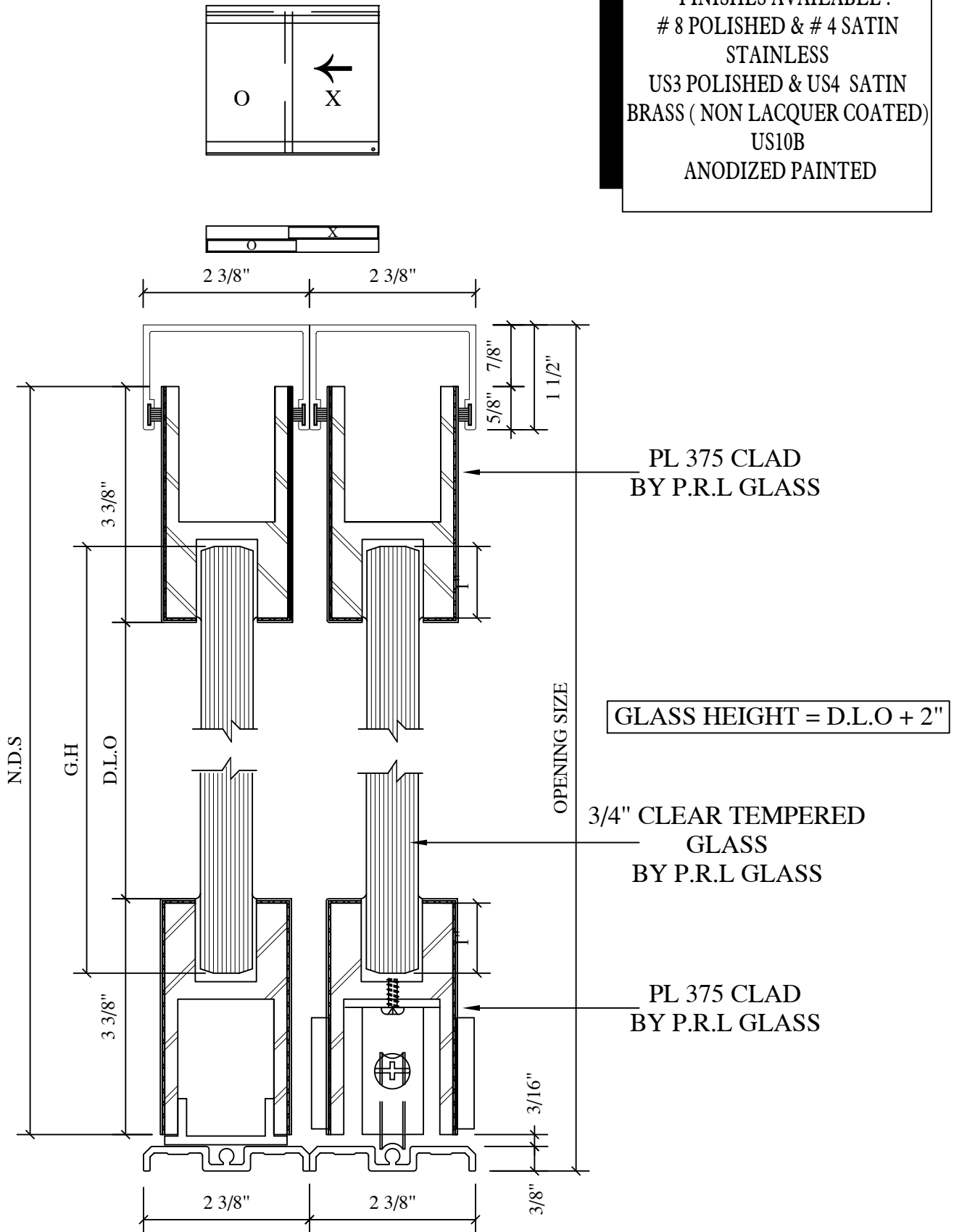

* FINISHES AVAILABLE :
8 POLISHED & # 4 SATIN
STAINLESS
US3 POLISHED & US4 SATIN
BRASS (NON LACQUER COATED)
US10B
ANODIZED PAINTED

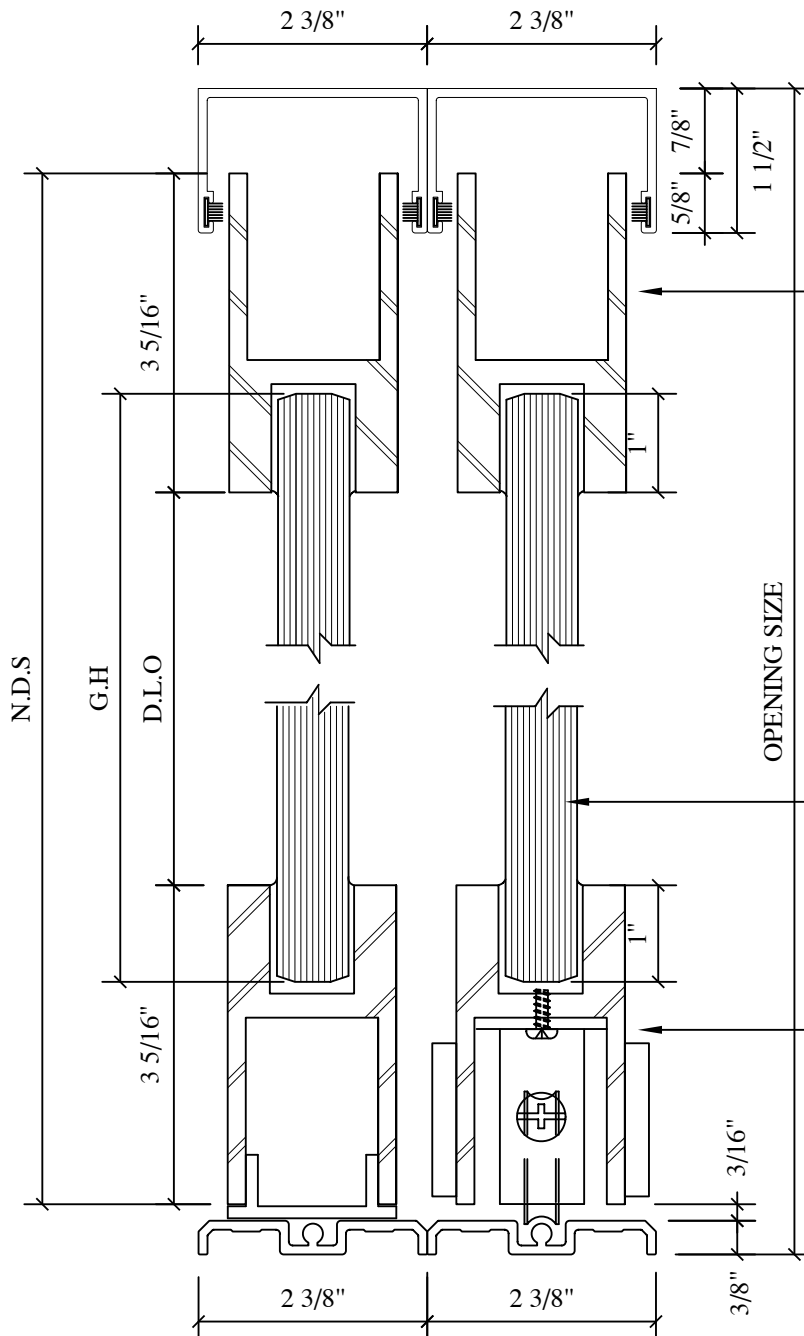
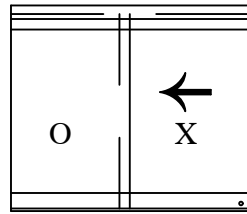

PL 375
BY P.R.L GLASS

GLASS HEIGHT = D.L.O + 2"

3/4" CLEAR TEMPERED
GLASS
BY P.R.L GLASS

PL 375
BY P.R.L GLASS

PRL

GLASS
SYSTEMS
INC.
PrIglass.com



PL375 CLAD BTM ROLL SYSTEM (O,X,X)

DWG NO.: BOTTOM ROLLING SLIDER1

DATE: 05/22/10

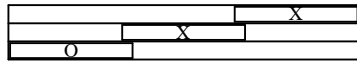
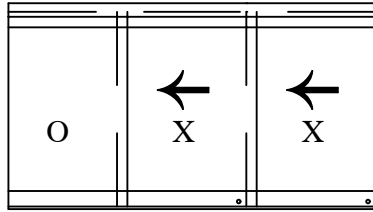

* FINISHES AVAILABLE :
8 POLISHED & # 4 SATIN
STAINLESS
US3 POLISHED & US4 SATIN
BRASS (NON LACQUER COATED)
US10B
ANODIZED PAINTED

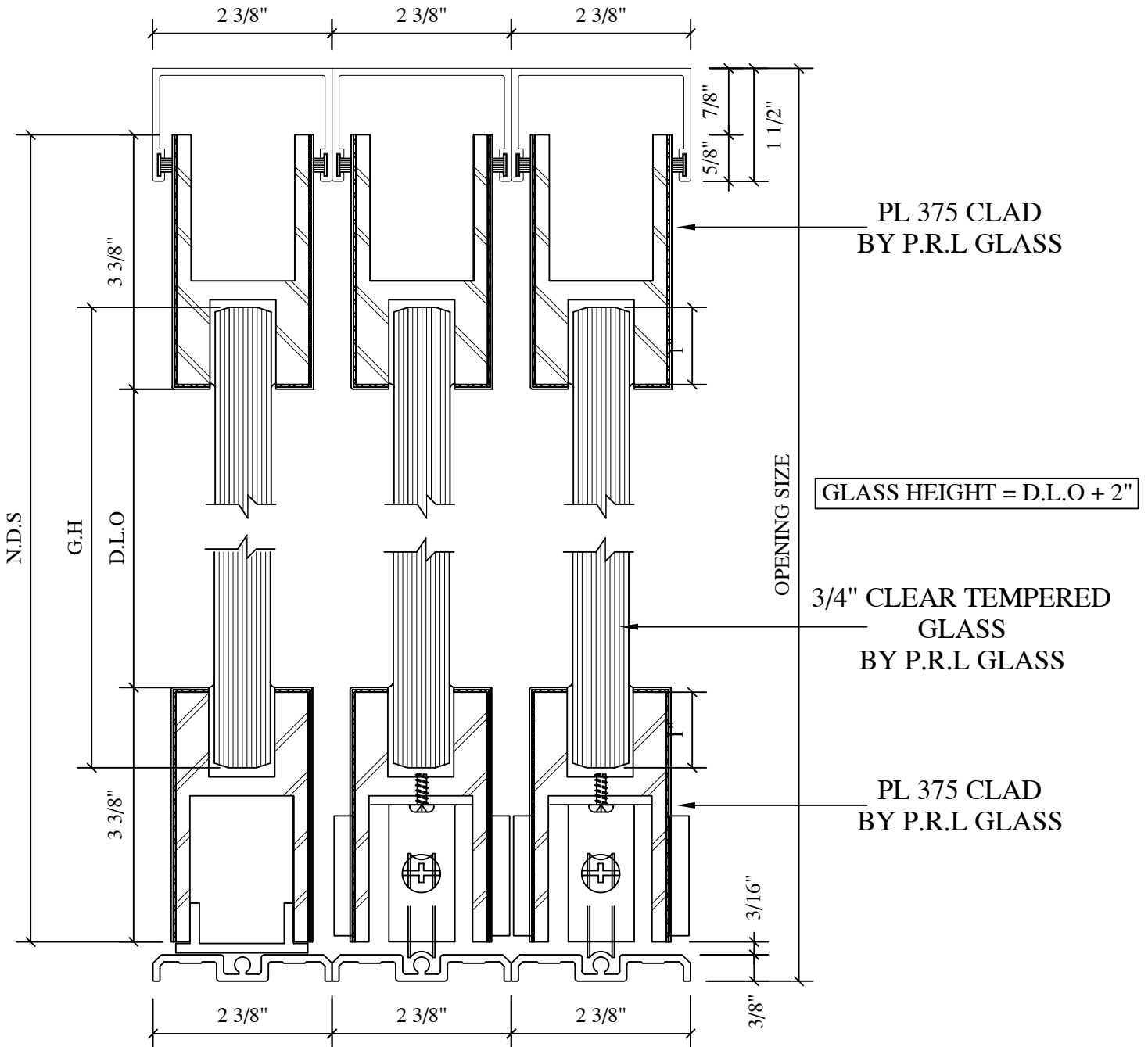

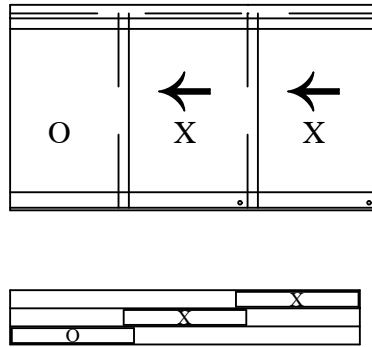

* FINISHES AVAILABLE :
8 POLISHED & # 4 SATIN
STAINLESS
US3 POLISHED & US4 SATIN
BRASS (NON LACQUER COATED)
US10B
ANODIZED PAINTED

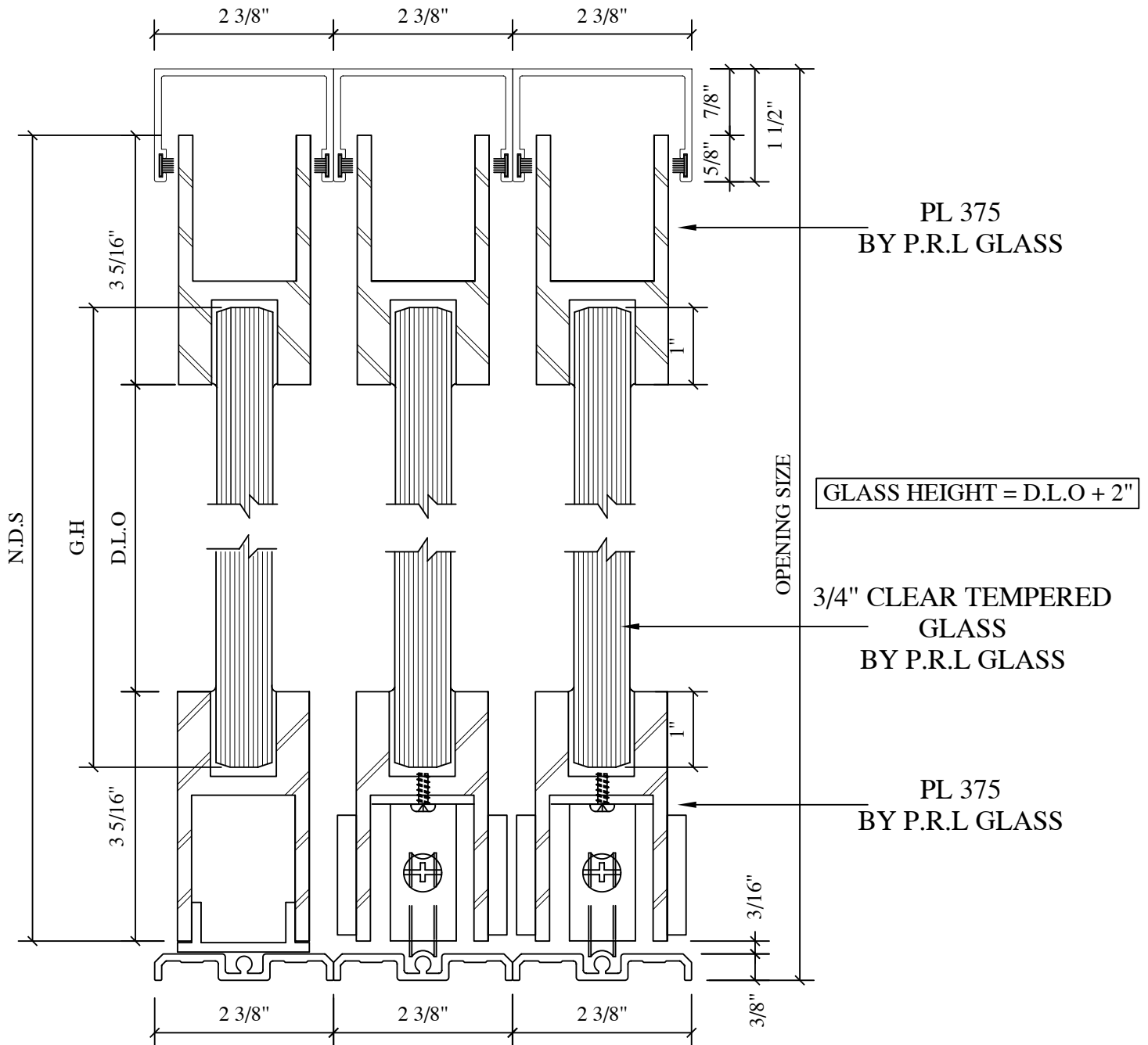

PL 375
BY P.R.L GLASS

GLASS HEIGHT = D.L.O + 2"

3/4" CLEAR TEMPERED
GLASS
BY P.R.L GLASS

PL 375
BY P.R.L GLASS

* FINISHES AVAILABLE :
8 POLISHED & # 4 SATIN
STAINLESS
US3 POLISHED & US4 SATIN
BRASS (NON LACQUER COATED)
US10B
ANODIZED PAINTED

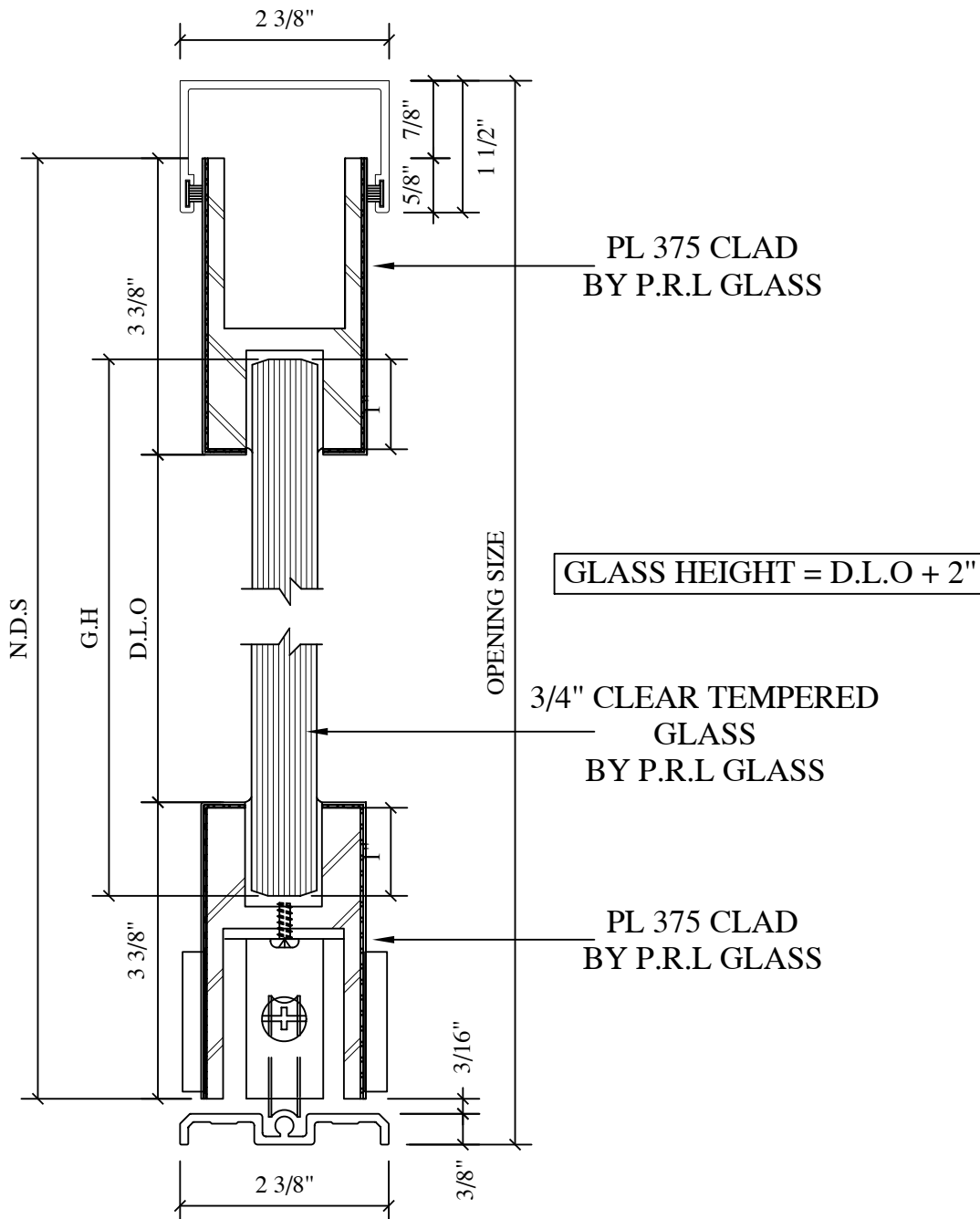
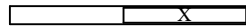
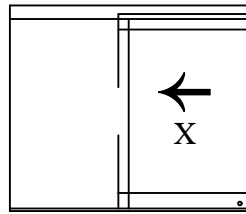

* FINISHES AVAILABLE :
8 POLISHED & # 4 SATIN
STAINLESS
US3 POLISHED & US4 SATIN
BRASS (NON LACQUER COATED)
US10B
ANODIZED PAINTED

